



marantz®

model PM551/PM451

Stereo Amplifier

MARANTZ DESIGN AND SERVICE

Using superior design and selected high grade components, MARANTZ company has created the ultimate in stereo sound.

Only **original MARANTZ parts** can insure that your MARANTZ product will continue to perform to the specifications for which it is famous.

Parts for your MARANTZ equipment are generally available to our National Marantz Subsidiary or Agent.

ORDERING PARTS:

Parts can be ordered either by mail or by telex. In both cases, correct part number has to be specified. If you order by mail, fulfil MARANTZ order forms.

The following information must be supplied to eliminate delays in processing your order:

1. Complete address
2. Complete part numbers and quantities required
3. Description of parts
4. Model number for which part is required
5. Way of shipment
6. Signature: any order form or telex must be signed otherwise such part order will be considered as null and void.

PARTS ORDERING

Parts may be ordered at the following addresses:

AUSTRIA
HORNYPHON
Vertriebsgesellschaft GmbH
Wienerbergstrasse 1
A 1101 Wien
Austria
Telex: 132.332

EIRE
MARANTZ IRELAND Ltd.
Newstead
Glionkeagh
Dublin 4
Telex: 25200

NORWAY
MARANTZ
DIVISION OF PHILIPS A/S
Sandstuveien 40
Oslo 6
Norway
Telex: 72640

KUWAIT
AL ALAMIAH ELECTRONICS
Ussama Building
Fahd al Saleem Street
P.O.Box 23781
Safat-Kuwait
Telex: 22694

SWITZERLAND
DYNAVOX ELECTRONICS
Route de Villars 105
1701 Fribourg
Switzerland
Telex: 942377

AUSTRALIA
MARANTZ AUSTRALIA
PTY., Ltd.
19 Chard Road
Brookvale, NSW 2100
Australia
Telex: 24121

FINLAND
MARANTZ
DIVISION OF OY PHILIPS Ab
Kaivokatu 8
00100 Helsinki
Finland
Telex: 124811

GREAT BRITAIN
MARANTZ AUDIO U.K. Ltd
Unit 15/16
Saxon Way Industrial Estate
Moor Lane
Harmondsworth UB7 OLW
Great Britain
Telex: 935196

SAUDI ARABIA
AL ALAMIAH ELECTRONICS
P.O.Box 5954
University Street
Riyadh 11432
Saudi Arabia
Telex: 201530

TURKEY
DOGRUOL Ltd.
I.M.C.
6 Blok N°6310
Unkapani
Istanbul
Turkey
Telex: 22085

BELGIUM
SVD DIVISION MARANTZ
Industrialaan 1
1720 Groot-Bijgaarden
Belgium
Telex: 24466

FRANCE
MARANTZ FRANCE
4 Rue Bernard Palissy
92600 Asnières
France
Telex: 611651

GREECE
ADAMCO S.A.
P.O.Box 21025
Hippocrates Street 188
Athens 11410
Greece
Telex: 216.795

SOUTH AFRICA
MARANTZ
DIVISION OF PHILIPS S.A.
Rainer House
Ove Street, 10
Doomfontein
Johannesburg
Telex: 483.456

MALTA
CACHIA & GALEA
Republic Street, 68D
Valetta
Telex: 1682

CHILE
MARANTZ
DIVISION OF PHILIPS S.A.
AV. Santa Maria, 0760
Casilla 2687
Santiago
Telex: 240.239

GERMANY
MARANTZ GERMANY GmbH
Max-Planck-Strasse 22
6072 Dreieich 1
Germany
Telex: 529821

ITALY
MARANTZ ITALIANA S.p.A.
Via Monte Napoleone 10
20121 Milano
Italia

SPAIN
PHONO S.A.
Ignacio Iglesias 10
Badalona (Barcelona)
Spain
Telex: 59355

U.S.A.
MARANTZ COMPANY, Inc.
National Service Department
P.O.Box 577
Chatsworth, CA 91311
U.S.A.

DENMARK
MARANTZ
DIVISION OF PHILIPS
SERVICE A/S
Prags Boulevard 80
Postbox 1919
DK-2300 København S
Denmark
Telex: 31201

THE NETHERLANDS
MARANTZ
De Limiet 3
4131 NR Vianen
The Netherlands
Telex: 47679

JAPAN
MARANTZ JAPAN, Inc.
35-1, 7-chome, Sagamiono
Sagamihara-shi, Kanagawa
Japan

SWEDEN
MARANTZ
DIVISION OF PHILIPS
Försäljning AB
Tegeluddsvägen 1
S-115 84 Stockholm
Sweden
Telex: 14060

All of the above locations are fully equipped to take care of your total service needs. Because various countries have differing configuration requirements, it is necessary that you contact the service facility in your particular country. In the event that there is no service location listed for your country, please, contact the nearest facility for the necessary assistance.

In case of difficulties, do not hesitate to contact the Technical Department at abovementioned address.

marantz®

TABLE OF CONTENTS

SECTION	PAGE
INTRODUCTION	1
1. SHOCK, FIRE HAZARD SERVICE TEST	1
2. P.W. BOARDS	1
3. TEST EQUIPMENT REQUIRED FOR SERVICING	2
4. VOLTAGE CONVERSION	2
5. CIRCUIT DESCRIPTION	3
6. BLOCK DIAGRAM	9
7. DIAGRAM AND COMPONENT LOCATIONS	10
7.1 Graphic Equalizer Assembly (PF00) Schematic Diagram and Component Locations	10
7.2 Visual Selector Assembly (PL00) Schematic Diagram and Component Locations	10
7.3 Input Selector Assembly (PS00) Schematic Diagram and Component Locations	11
7.4 VD Input Assembly (PV00) Schematic Diagram and Component Locations	11
7.5 VCR EASY Remote Input Assembly (PW00) Schematic Diagram and Component Locations	11
7.6 Front Switch Assembly (PU00) Schematic Diagram and Component Locations	13
7.7 Main Amp. Assembly (P700) Schematic Diagram and Component Locations	14
7.8 Volume Indicator Assembly (PU50) Schematic Diagram and Component Locations	14
7.9 Speaker Switch Assembly (PT00) Schematic Diagram and Component Locations	15
8. EXPLODED VIEW AND PARTS LIST	16
9. ELECTRICAL PARTS LIST	20
10. TECHNICAL SPECIFICATIONS	24
11. SCHEMATIC DIAGRAM	26

How to use this service manual

- The "Common parts" which Marantz Japan, Inc. has established are eliminated from this service manual.
- These "Common parts" are applied to all models in the service manuals arranged and issued by MJI.
- To indicate clearly the common parts in the schematic diagram, a line is drawn above or under the Ref. Desig. No. of applicable parts.
- "Common parts" can be supplied from the Marantz service center as ever.
In case of ordering, please establish the parts number of 10 figures following the procedure mentioned in this service manual "How to establish the parts number for common parts".

(NOTE)

When you order parts to the Marantz parts center, please take notice of the following points.

- 1) Please correctly write the parts number of 10 figures following the rule.
- 2) Since ordering parts by the Ref. Desig. No. or ratings indicated in the schematic diagram does not satisfy the above conditions, the Marantz parts supply system does not work properly.
As this case is apt to cause a trouble, please pay attention to it.

MODEL PM451/PM551 STEREO AMPLIFIER

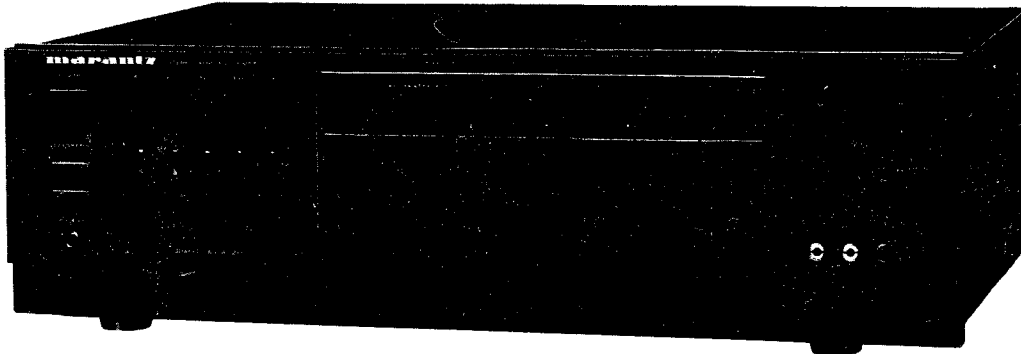

Model PM551

INTRODUCTION

This service manual was prepared for use by Authorized Warranty Stations and contains service information for the Marantz Model PM451/PM551 Stereo Amplifier.

Servicing information and voltage data included in this manual are intended for use by knowledgeable and experienced personnel only. All instructions should be read carefully. No attempt should be made to proceed without a good understanding of circuitry operation.

The parts list furnishes complete ordering information. Most replacement parts should be ordered from the Marantz Company. However, a simple description is included for parts which can be obtained locally.

1. SHOCK, FIRE HAZARD SERVICE TEST

CAUTION: After servicing this appliance and prior to returning to customer, measure the resistance between either primary AC cord connector pins (with unit NOT connected to AC mains and its Power switch ON), and the face or front Panel of product and controls and chassis bottom.

Any resistance measurement less than 1 Megohms should cause unit to be repaired or corrected before AC power is applied, and verified before return to user/customer.

Ref. UL Standard No. 1270. Para. 66. 3. D (Mandatory Test after servicing Electrical Appliances, effective 7-1-83).

2. P.W. BOARDS

As can be seen from the circuit diagram the chassis of Model PM451/PM551 consists of the following units. Each unit mounted on a printed circuit board is described within the square enclosed by a bold dotted line on the circuit diagram.

1. **Main Amp mounted on P.W. Board P700**
2. **Graphic Equalizer mounted on P.W. Board PF00**
3. **Visual Selector mounted on P.W. Board PL00**
4. **Input Selector mounted on P.W. Board PS00**
5. **Speaker Switch mounted on P.W. Board PT00**
6. **Front Switch mounted on P.W. Board PU00**
7. **Volume Indicator mounted on P.W. Board PU50**
8. **VD Input mounted on P.W. Board PV00**
9. **VCR EASY**
Remote Input mounted on P.W. Board PW00

3. TEST EQUIPMENT REQUIRED FOR SERVICING

This table lists the test equipment required for servicing the Model PM451/PM551 Stereo Amplifier.

Item	Use
Distortion Analyzer	Distortion measurements
Audio Oscillator	Sinewave and squarewave signal source
AC VTVM	Voltage measurements (AC)
Oscilloscope	Waveform analysis and trouble shooting and ASO alignment
Circuit Tester	Trouble shooting
DC VTVM	Voltage measurements (DC)
AC Wattmeter	Monitors primary power to amplifier
Line Voltmeter	Monitors potential of primary power to amplifier
Variable Autotransformer (0 ~ 140V AC, 10A)	Adjust level of primery power to amplifier
Shorting Plug	Shorts amplifier input to eliminate noise pickup

4. VOLTAGE CONVERSION

To convert the unit to a different power source voltage, change the position as illustrated in the drawing below.

CAUTION: DISCONNECT POWER SUPPLY CORD FROM AC OUTLET BEFORE CONVERTING VOLTAGE. DO NOT DISASSEMBLE THE VOLTAGE SELECTOR ABSOLUTELY.

Note on safety:

Symbol \triangle Fire or electrical shock hazard. Only original parts should be used to replace any part marked with symbol \triangle . Any other component substitution (other than original type), may increase risk of fire or electrical shock hazard.

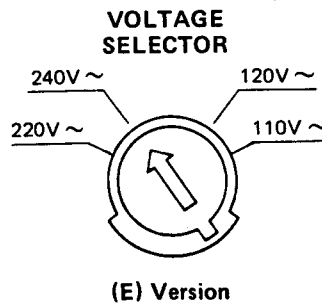
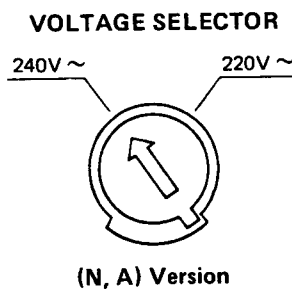
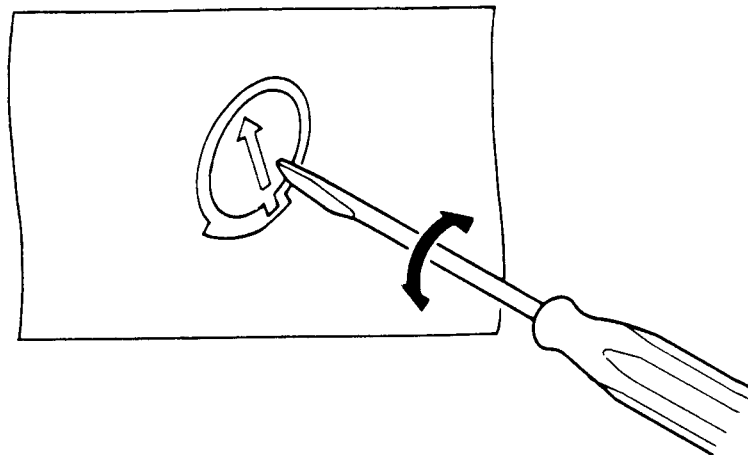

M2949

5. CIRCUIT DESCRIPTION

SINGLE-CHIP 4-BIT MICROCOMPUTER LC6502C (QU01)

BLOCK DIAGRAM

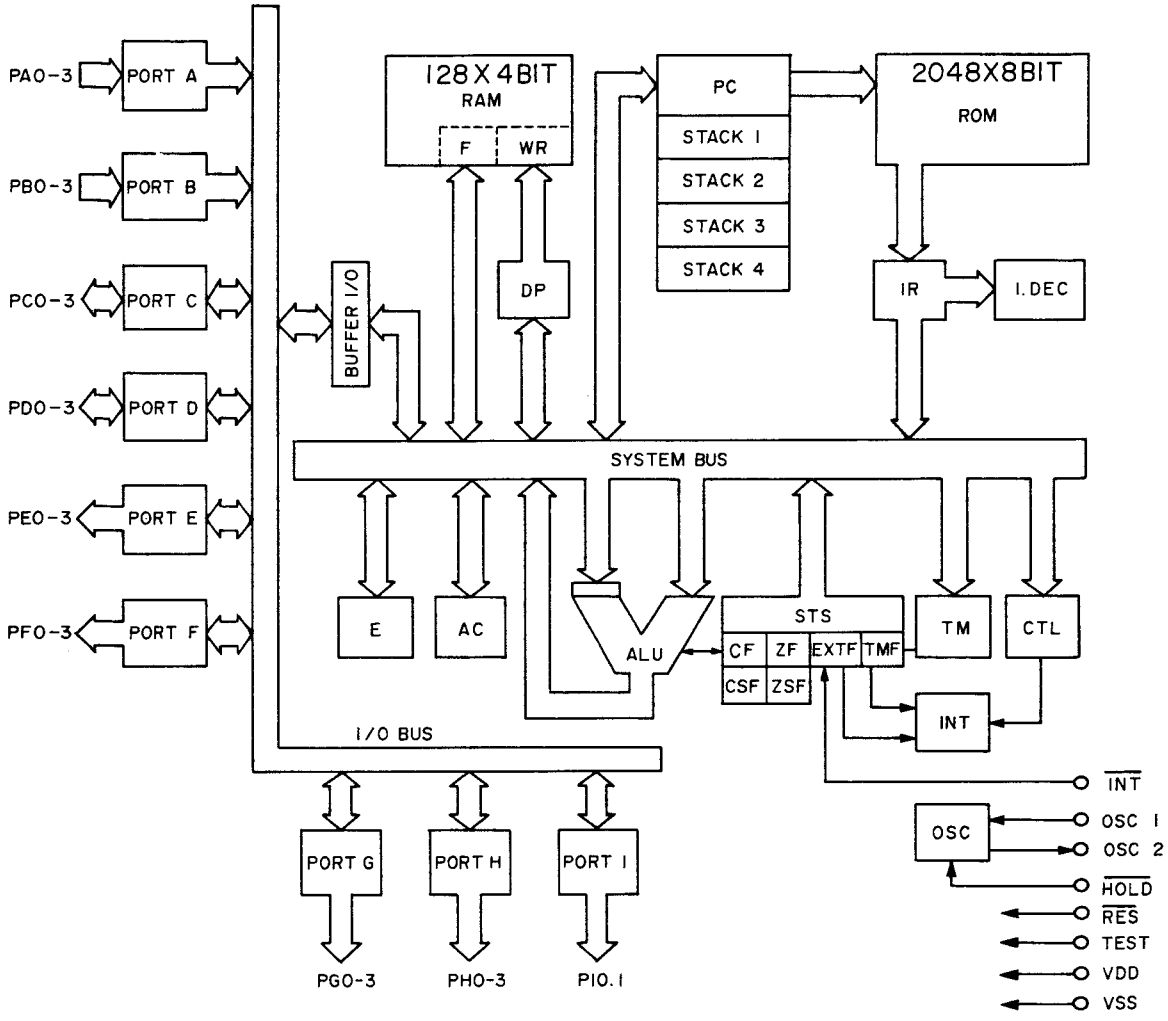

RAM: data memory
 F: flag
 WR: working register
 AC: accumulator
 ALU: logical operator unit
 DP: data pointer
 E: E register
 CTL: control register
 OSC: oscillator circuit
 TM: timer
 STS: status register

ROM: program memory
 PC: program counter
 INT: interrupt control
 IR: instruction register
 I. DEC: instruction decoder
 CF, CSF: carry flag, carry save flag
 ZF, ZSF: zero flag, zero save flag
 EXTF: external interrupt request flag
 TMF: internal interrupt request flag

M2950

Terminal Connections

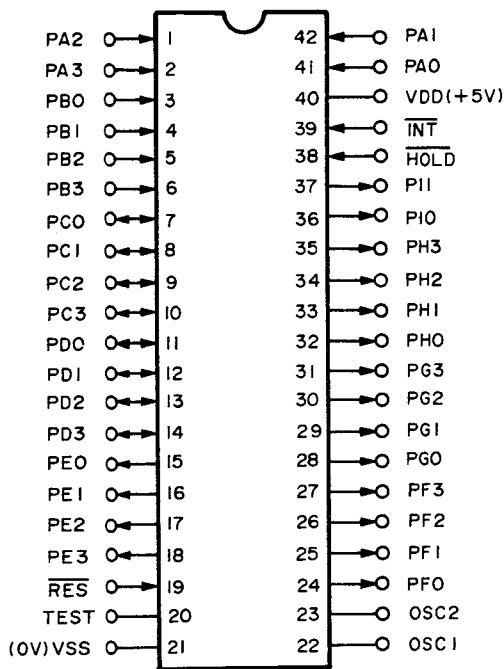

Terminal Function

Terminal Name	I/O	Function
INT	Input	Pseudo interrupt request input terminal.
HOLD	Input	Hold mode request input terminal.
RES	Input	Reset input terminal.
PA3-0	Input	Input ports A3 to A0 In input mode, 4-bit input and bit test are allowed. Used for HALT mode release and request input.
PB3-0	Input	Input ports B3 to B0 In input mode, 4-bit input and bit test are allowed.
PC3-0	I/O	I/O ports C3 to C0 In input mode, 4-bit input and bit test are allowed. In output mode, 4-bit output, bit set/reset output are allowed.
PD3-0	I/O	I/O ports D3 to D0 In input mode, 4-bit input and bit test are allowed. In output mode, 4-bit output, bit set/reset output are allowed.
PE3-0	Output	Output ports E3 to E0 4-bit output and bit set/reset are allowed. Input of output latch contents in 4-bit units and testing of output latch of bit is possible.
PF3-0	Output	Output ports F3 to F0 4-bit output and bit set/reset are allowed. Input of output latch contents in 4-bit units and testing of output latch of bit is possible.
PG3-0	Output	Output port G3 to G0 4-bit output and bit set/reset are allowed. Input of output latch contents in 4-bit units and testing of output latch of bit is possible.
PH3-0	Output	Output ports H3 to H0 4-bit output and bit set/reset are allowed. Input of output latch contents in 4-bit units and testing of output latch of bit is possible.
PI0, 1	Output	Output ports I0, 1 2-bit output and bit set/reset are allowed. Input of output latch contents in 4-bit units and testing of output latch of bit is possible.
OSC1	Input	Terminal operated with clock signal externally supplied. A ceramic resonator and CR are connected to the space between the X'tal and this terminals when using the local clock signal oscillator.
OSC2	I/O	External terminal of the resonance circuit for local clock signal oscillation.
VDD	Input	Power terminal, usually connected to +5V.
VSS		Connected to 0V of power supply.
TEST	Input	LSI test terminal, usually connected to VSS (0V).

Maximum Ratings ($T_a = 25^\circ\text{C}$, $V_{SS} = 0\text{V}$)

Item	Symbol	Condition	Min.	Max.	Unit
Maximum supply voltage	V_{DD} max.		-0.3	+7	V
Input voltage	V_{IN}		-0.3	$V_{DD}+0.3$	V
Output voltage	V_{OUT}	Output transistor OFF	-0.3	$V_{DD}+0.3$	V
Allowable power dissipation	P_d max.	-30°C to $+70^\circ\text{C}$		350	mW
Ambient operating temperature	T_{opg}		-30	+70	$^\circ\text{C}$
Ambient storage temperature	T_{stg}		-55	+125	$^\circ\text{C}$

ELECTRON VOLUME IC TC9177P (QS03)

BLOCK DIAGRAM

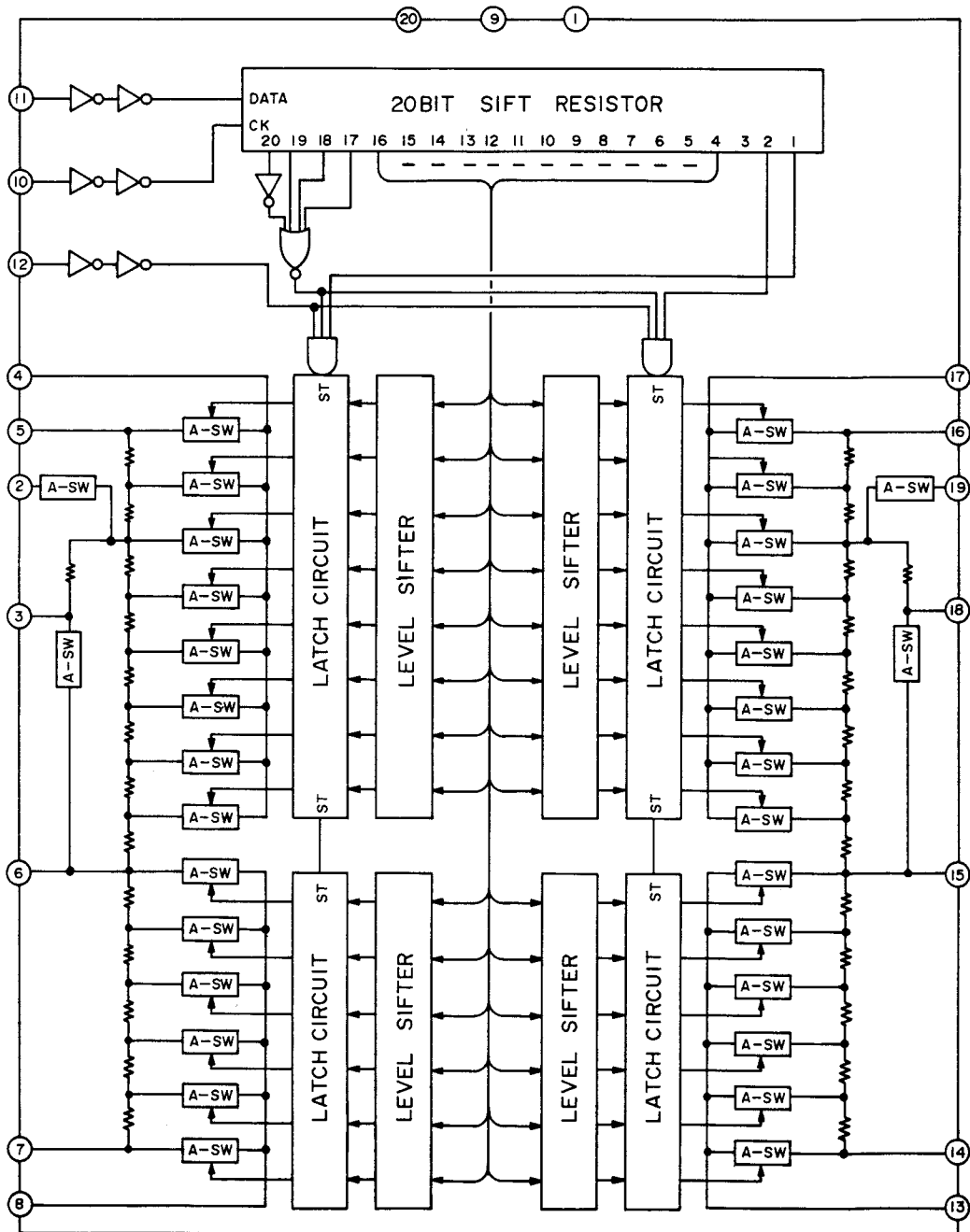

Terminal Connections

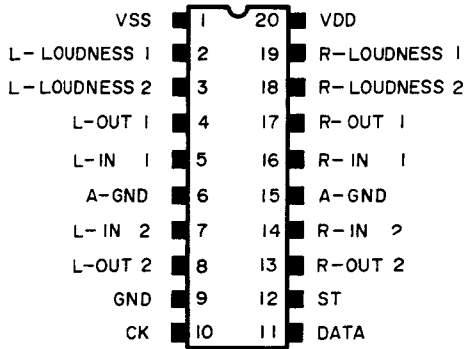

Terminal Function

Pin No.	Name	Function Description
2, 3 18, 19	L-LOUDNESS 1, 2 R-LOUDNESS 1, 2	Pins for loudness When loudness data is input, these pins becomes -20 dB dampened pins. Loudness control is possible through the connection of high and low range boosting circuits to these pins.
4, 17	L-OUT ₁ R-OUT ₁	10 dB step attenuator output. The signal applied to IN is attenuated in 8 10 dB steps from 0 to 70 dB.
5, 16	L-IN ₁ R-IN ₁	10 dB attenuator input.
6, 15	A-GND	AC ground pin.
7, 14	L-IN ₂ L-IN ₂	2 dB attenuator pin.
8, 13	L-OUT ₂ R-OUT ₂	2 dB attenuator output. The signal applied to IN is attenuated in 5 2 dB steps from 0 to 8 dB.
11	DATA	Data input for amount of attenuation and channel selection. Input by CK signal, configured in 20 bits.
10	CK	Clock input. Clock input for fetching data from DATA pin.
12	ST	Strobe input. The data for the amount of attenuation and channel selection fetched from the DATA and CK pins is latched when this pin is "high". The previous data remains effective when a high level is not applied to this pin.
20	VDD	Pin for (+) voltage.
9	GND	Ground pin.
1	VSS	Pin for (-) voltage.

Maximum Ratings (Ta = 25°C)

Item	Symbol	Ratings	Unit
Supply voltage	VDD	VSS-0.3 ~ VSS+36	V
Input voltage	VIN	VSS-0.3 ~ VDD+0.3	V
Power dissipation	PD	300	mW
Operating temperature	Topr	-30 ~ 75	°C
Storage temperature	Tstg	-55 ~ 125	°C

Electrical Characteristics ($V_{DD} = 15V, V_{SS} = -15V, T_a = 25^\circ C$)

Item	Symbol	Test Condition	Min.	Typ.	Max.	Unit
Operating power voltage range	$V_{DD}-V_{SS}$		7.5	~	32	V
Operating supply current	I_{DD}			0.5	3.0	mA
Input voltage	"H" V_{IH}	DATA, CK, ST terminal	4.0	~	$V_{DD}+0.3$	V
Input voltage	"L" V_{IL}		-0.3	~	1.0	V
Total resistance value (ATT ₁)	R_{ATT1}		90	120	160	K Ω
Total resistance value (ATT ₂)	R_{ATT2}		10	14	20	K Ω
Step error (ATT ₁)	STEP(1)	$f_{in}=DC\sim 20\text{ kHz } R_L=\infty$	0 ~ 30 dB	10	10.8	dB
			-40 ~ 70 dB		8.8	
Step error (ATT ₂)	STEP(2)	$f_{in}=DC\sim 20\text{ kHz } R_L=\infty$	-1.2	2	2.8	dB
Total harmonic distortion (ATT ₁)	THD(1)	$f_{in}=20\sim 20\text{ kHz}, V_{in}=1.0V_{rms} 0\text{ dB}$		0.003	0.005	%
Total harmonic distortion (ATT ₂)	THD(2)	$f_{in}=20\sim 20\text{ kHz}, V_{in}=1.0V_{rms} 0\text{ dB}$		0.003	0.005	%
Maximum amount of attenuation	ATT(max.)		90			dB
Output noise voltage	V_N	0 dB Position $f_{out}=20\sim 20\text{ kHz } R_g=1K\Omega$		2	10	μV_{rms}
Channel separation	C.S	$V_{in}=1\text{ Vrms } f_{in}=1\text{ kHz}$	80			dB

CONTROL INPUT SECTION

Maximum operating frequency	$f_{(max)}$				500	kHz
Minimum clock width ("H")	$T_{CK(H)}$		1.0			μsec
Minimum clock width ("L")	$T_{CK(L)}$		1.0			μsec

HIGH VOLTAGE RESISTING ANALOG FUNCTION SWITCH ARRAY TC9163N (QS01)

BLOCK DIAGRAM

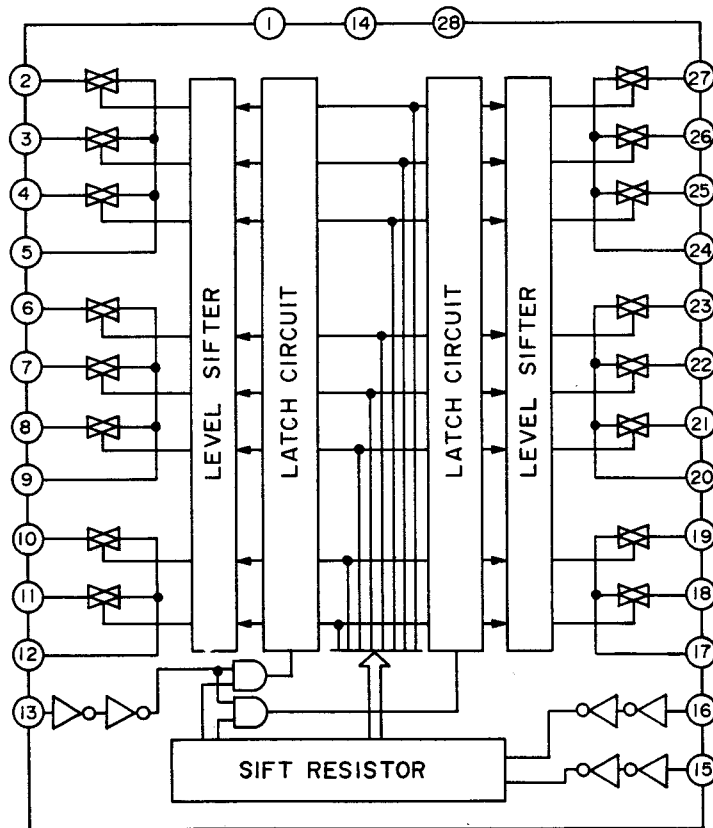

Terminal Connections

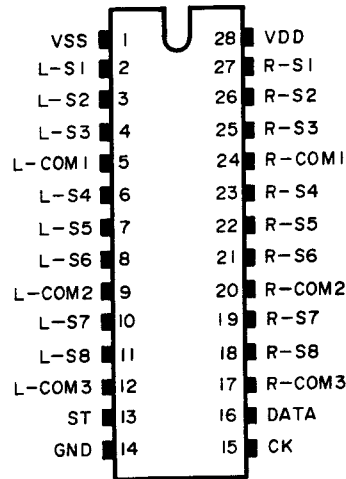

Maximum Ratings

Item	Symbol	Ratings	Unit
Supply voltage (1)	V _{DD} V _{SS}	34	V
Supply voltage (2)	V _{DD} GND	17	V
Input voltage	V _{IN}	V _{SS} -0.3 ~ V _{DD} +0.3	V
Power dissipation	P _D	300	mW
Operating temperature	T _{opr}	-30 ~ 75	°C
Storage temperature	T _{stg}	-55 ~ 125	°C

Electrical Characteristics (V_{DD}=16V, V_{SS}=-16V, GND=0V, T_a=25°C)

Item	Symbol	Test Condition	Min.	Typ.	Max.	Unit
Operating supply voltage (1)	V _{DD} -GND		8	~	16	V
Operating supply voltage (2)	GND-V _{SS}		-8	~	-16	V
Operation supply current	I _{DD}	V _{DD} =16V, V _{SS} =-16V, GND=0V	-	~	3	mA
Backup voltage	V _B		4	~	16	V
Backup current	I _B	V _{DD} =4.0V, V _{SS} =GND=0V	-	1	10	μA
High level input voltage	V _{IH}	V _{DD} =16V, CK, DATA, ST	4	-	16	V
Low level voltage	V _{IL}	V _{DD} =16V, CK, DATA, ST	0	-	10	V
Operating minimum pulse width	t _{in}		5	-	-	μsec
Switch ON resist.	R _{ON}		-	100	200	Ω
Total harmonic distortion.	THD	f _{in} =0~20 kHz, V _{in} =1V _{rms}	-	0.002	0.005	%
Nois voltage.	V _{NO}	f=20~50 kHz	-	2	10	μV _{rms}

1. BLOCK DIAGRAM

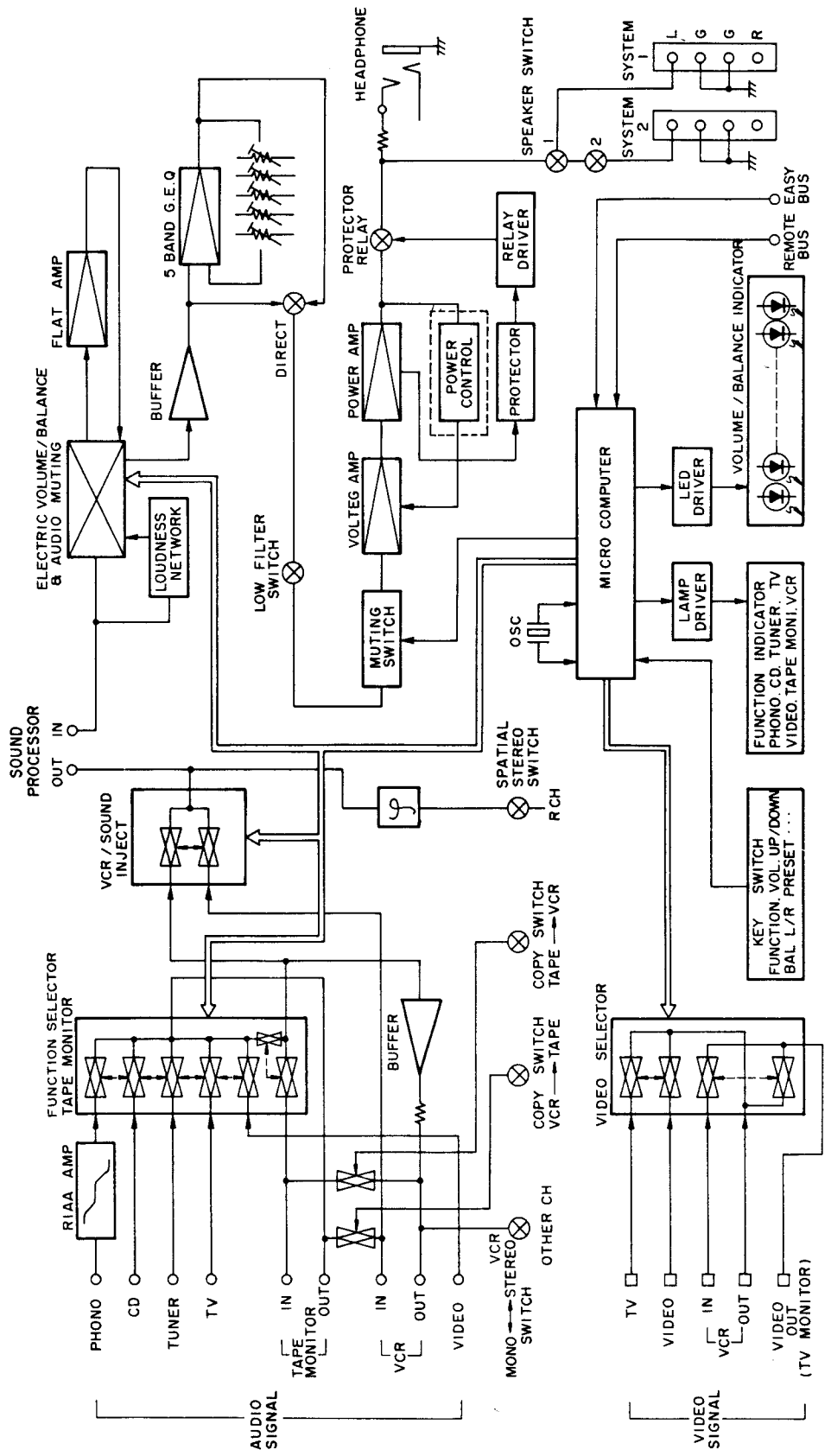

PM551 ONLY

M2956

7.3 Input Selector Assembly (PS00) Schematic Diagram and Component Locations

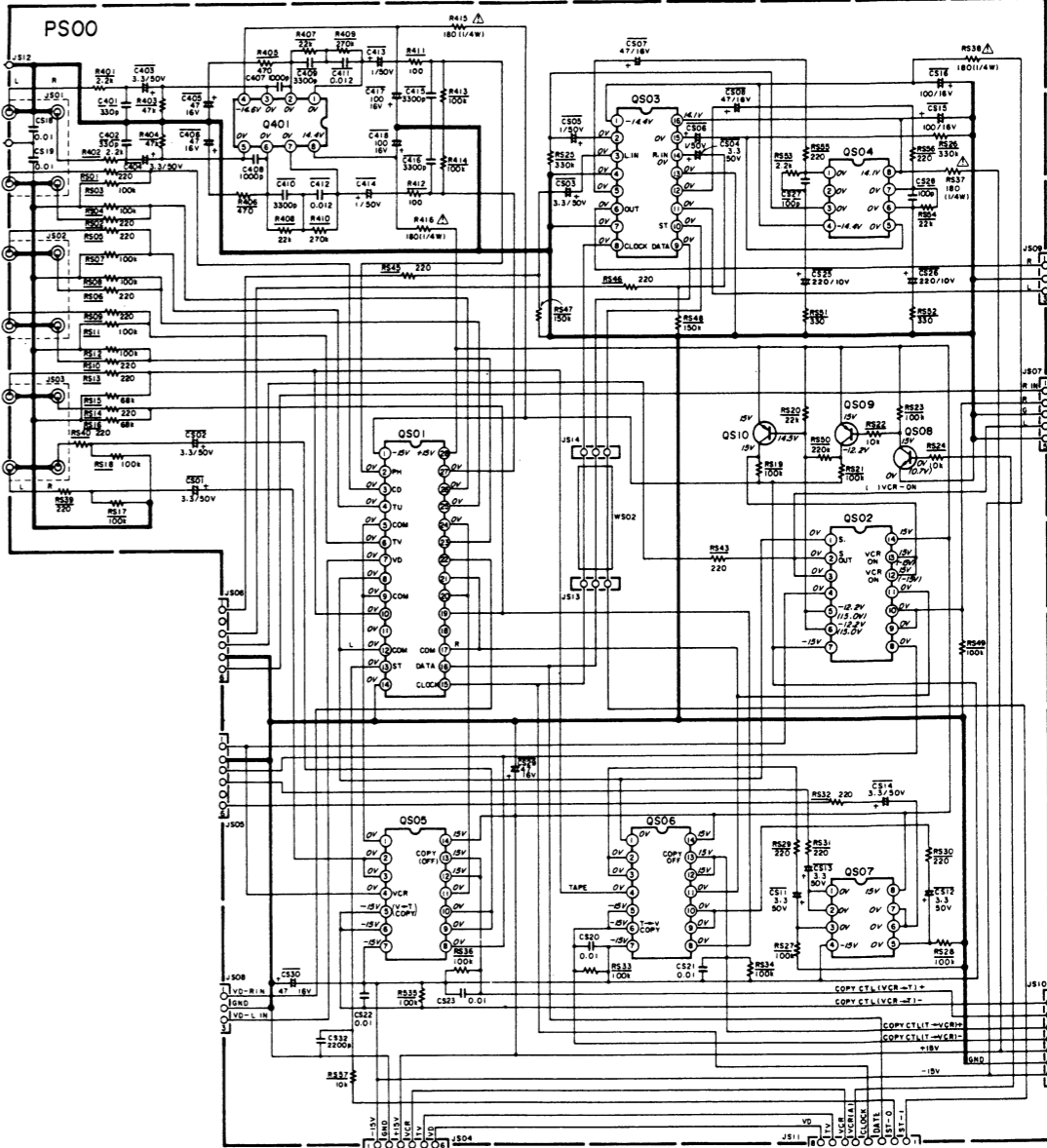

7.4 VD Input Assembly (PV00) Schematic Diagram and Component Locations

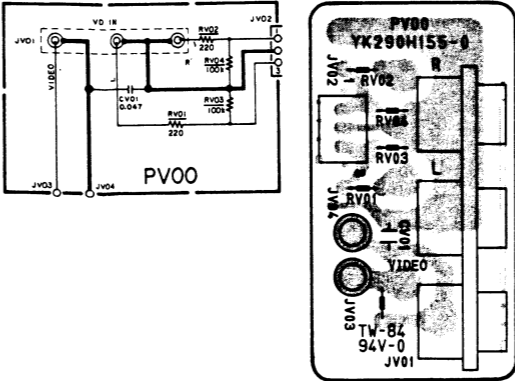

7.5 VCR EASY Remote Input Assembly (PW00) Schematic Diagram and Component Locations

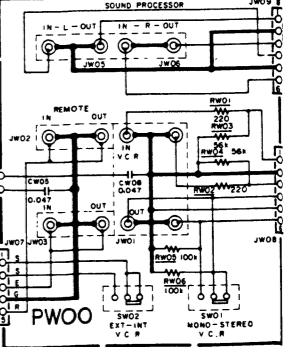

7. DIAGRAM AND COMPONENT LOCATIONS

7.1 Graphic Equalizer Assembly (PF00) Schematic Diagram and Component Locations

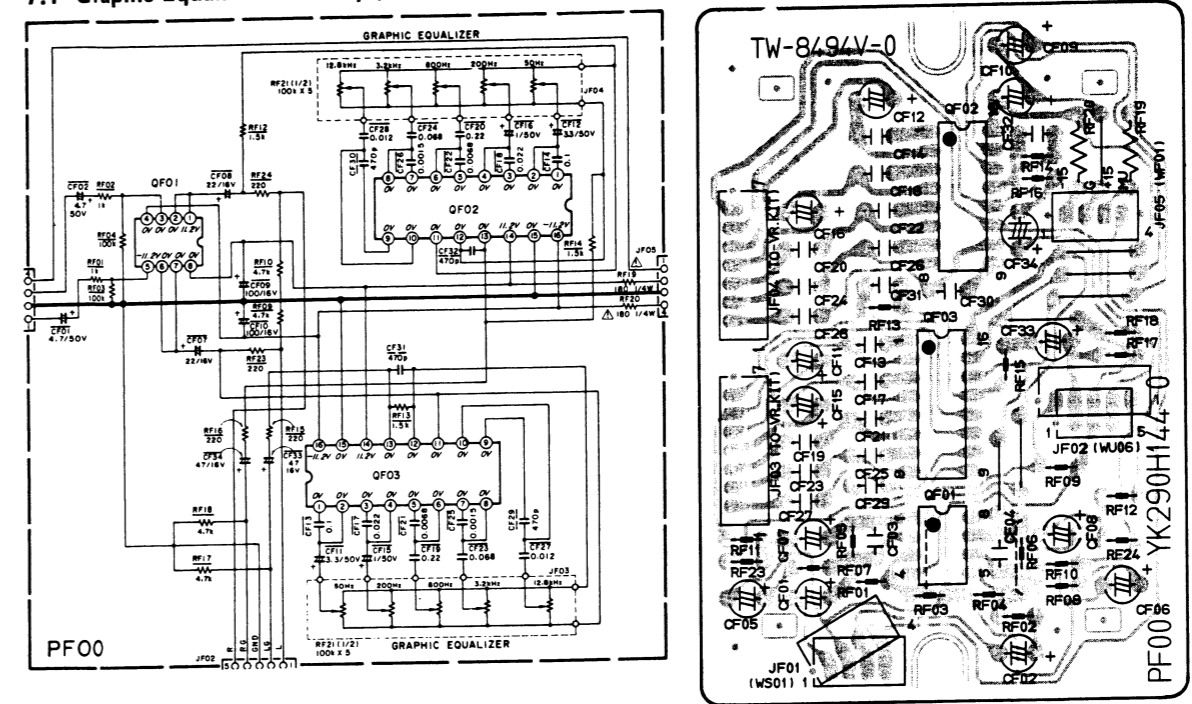

7.2 Visual Selector Assembly (PL00) Schematic Diagram and Component Locations

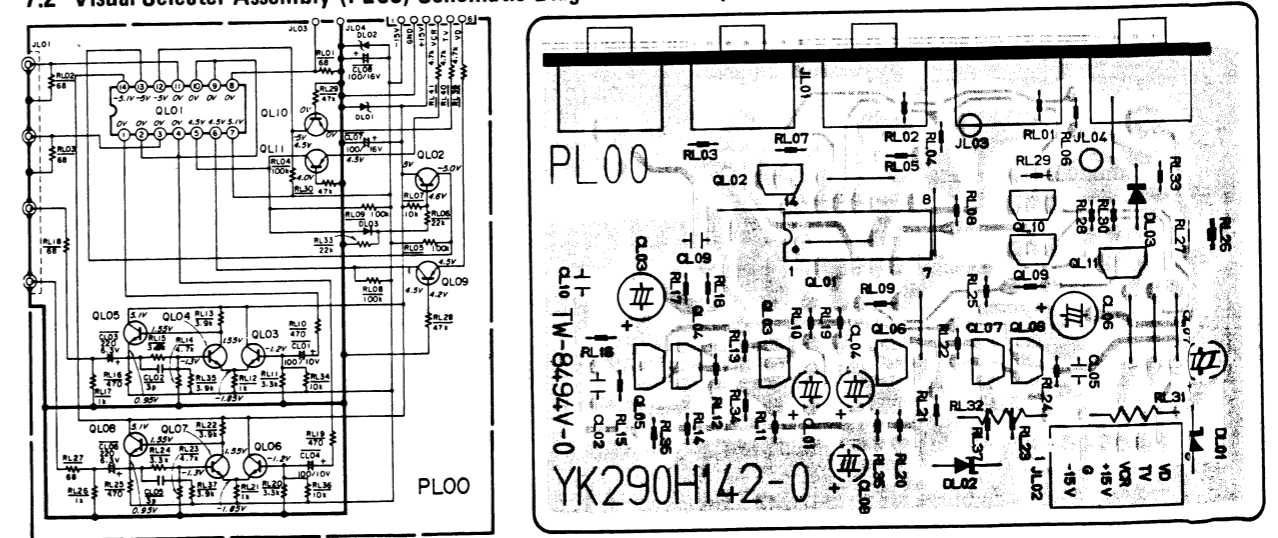

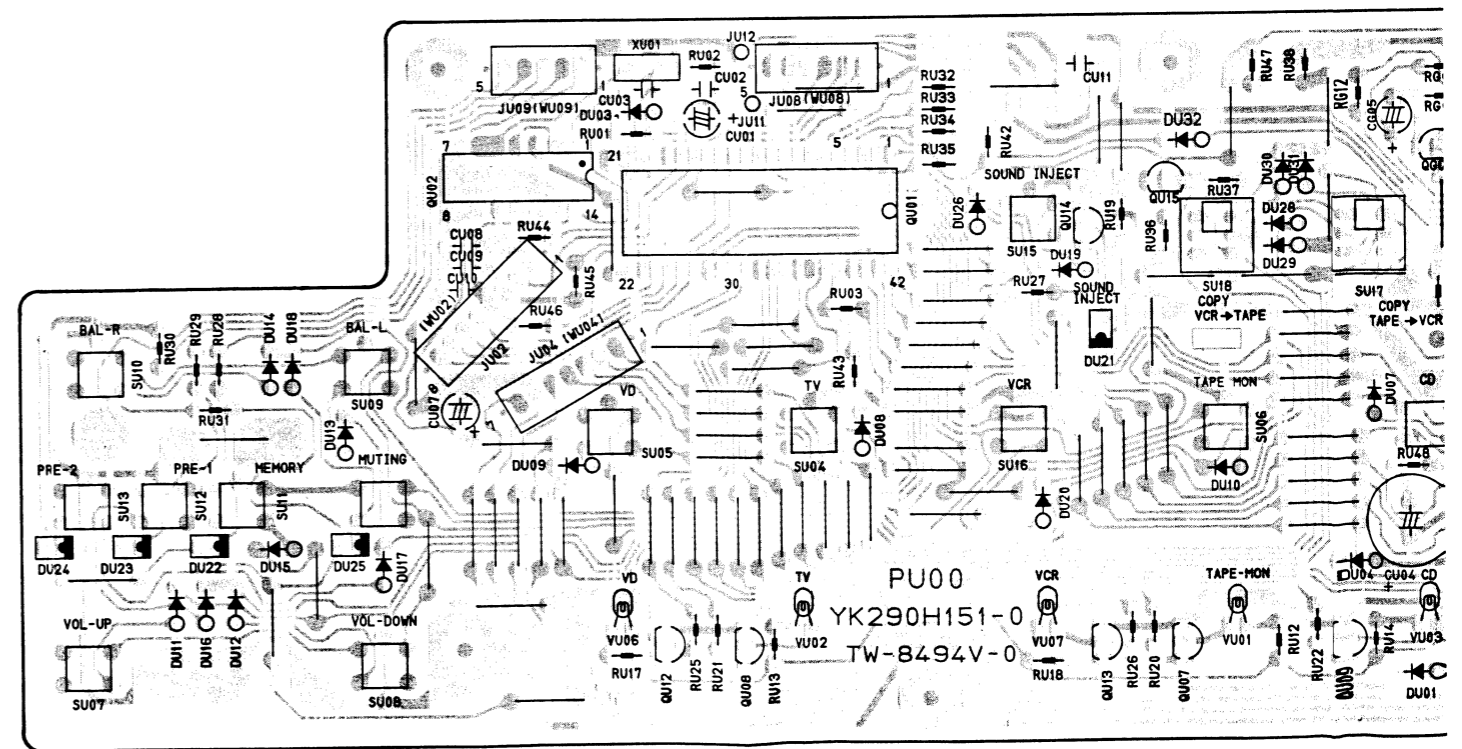
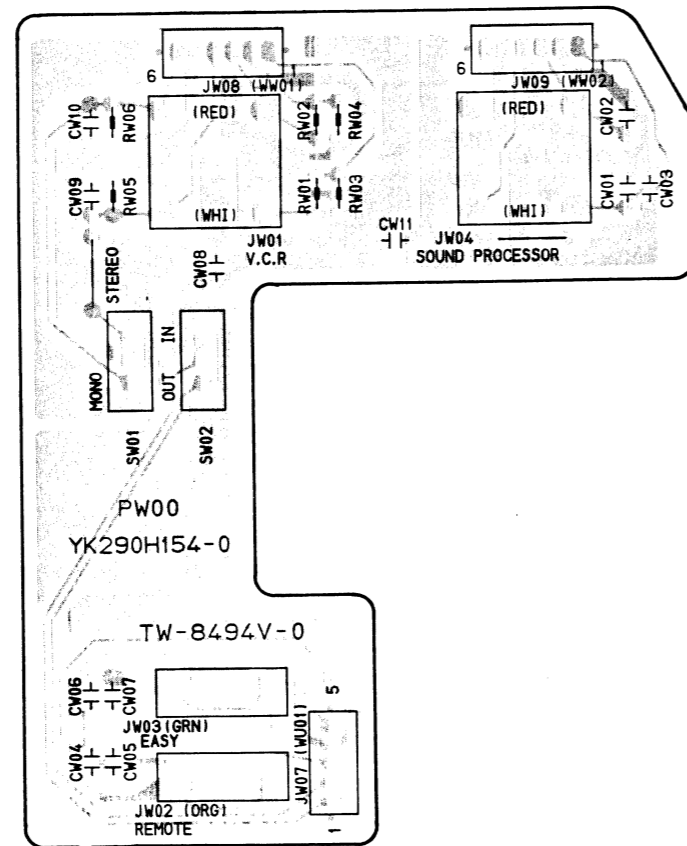
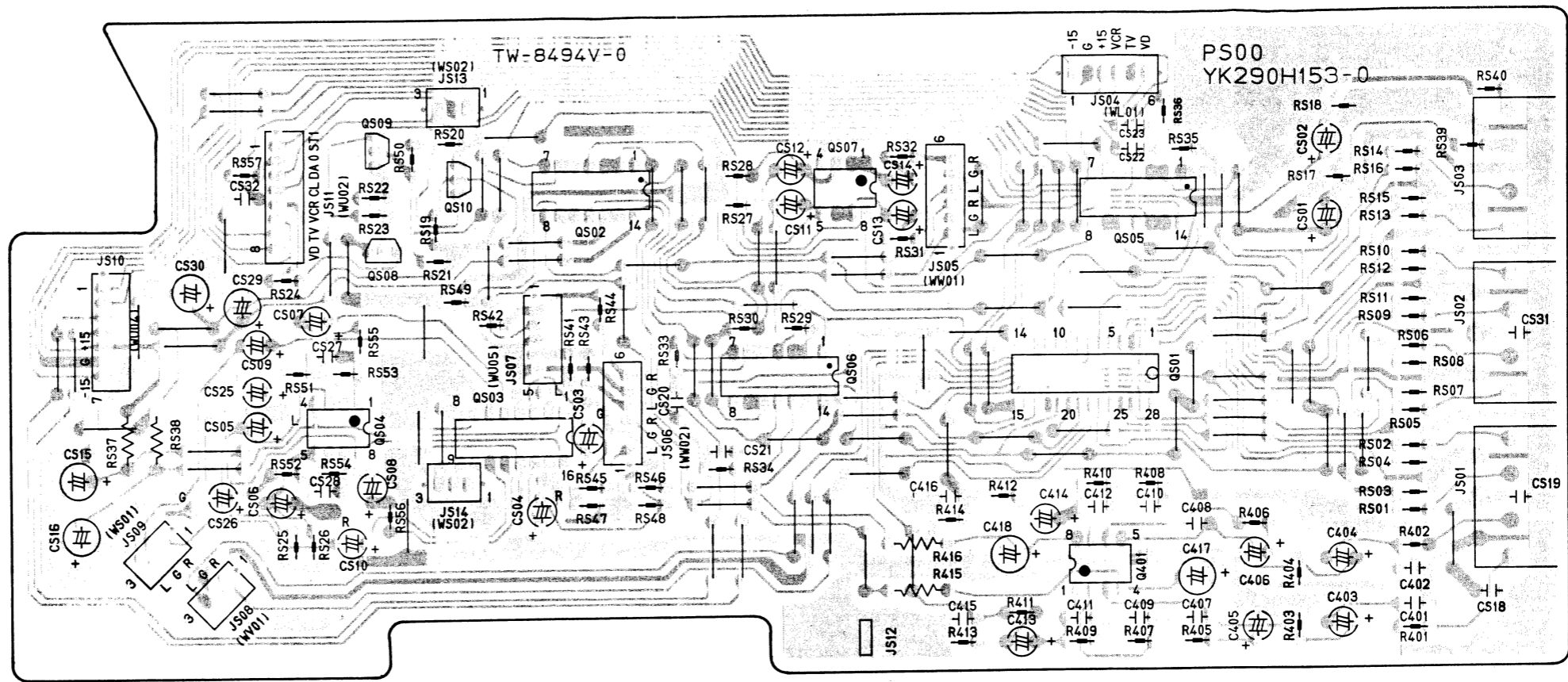

H2959

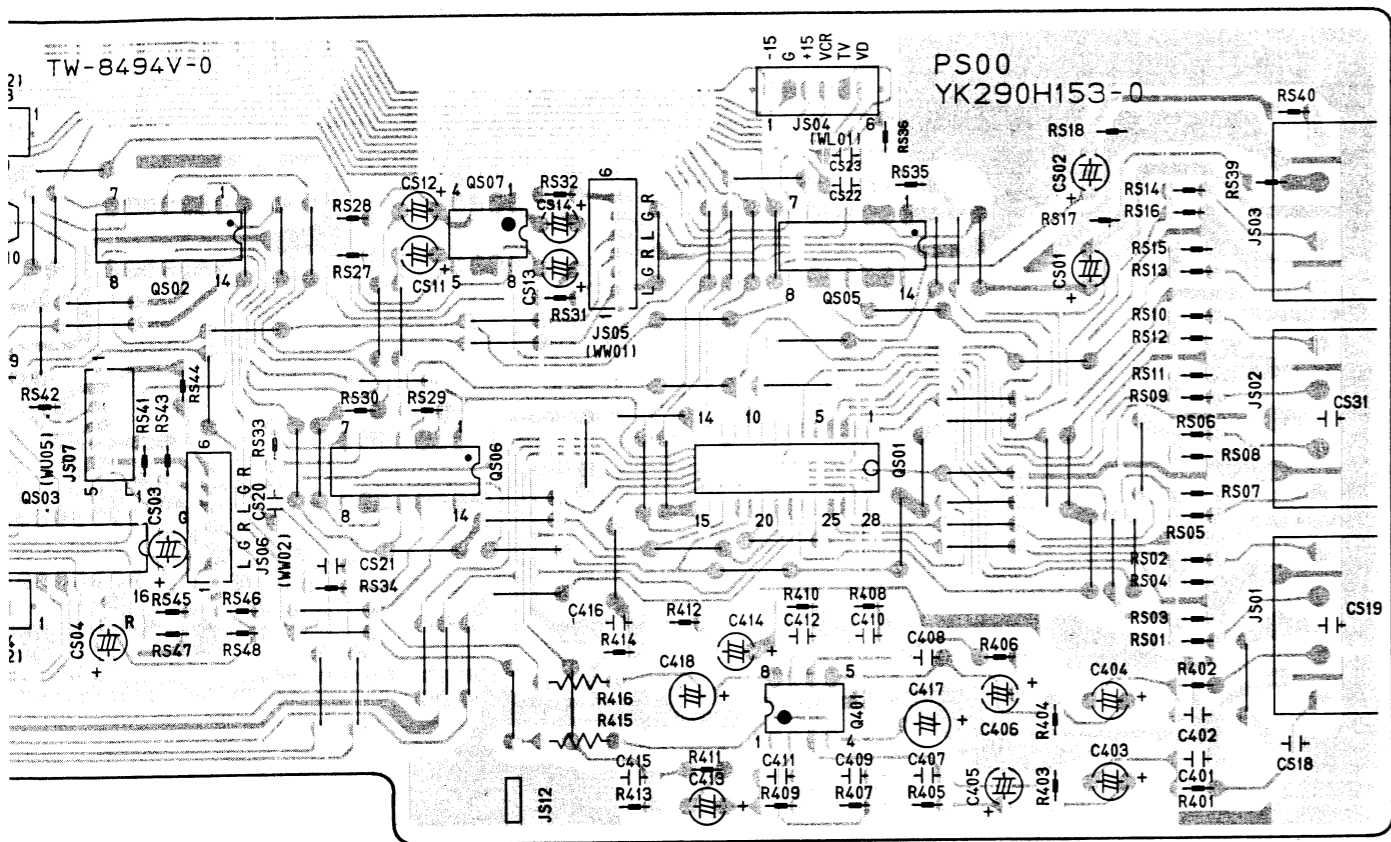

7.6 Front Switch Assembly (PU00) Schematic Diagram and Component Locations

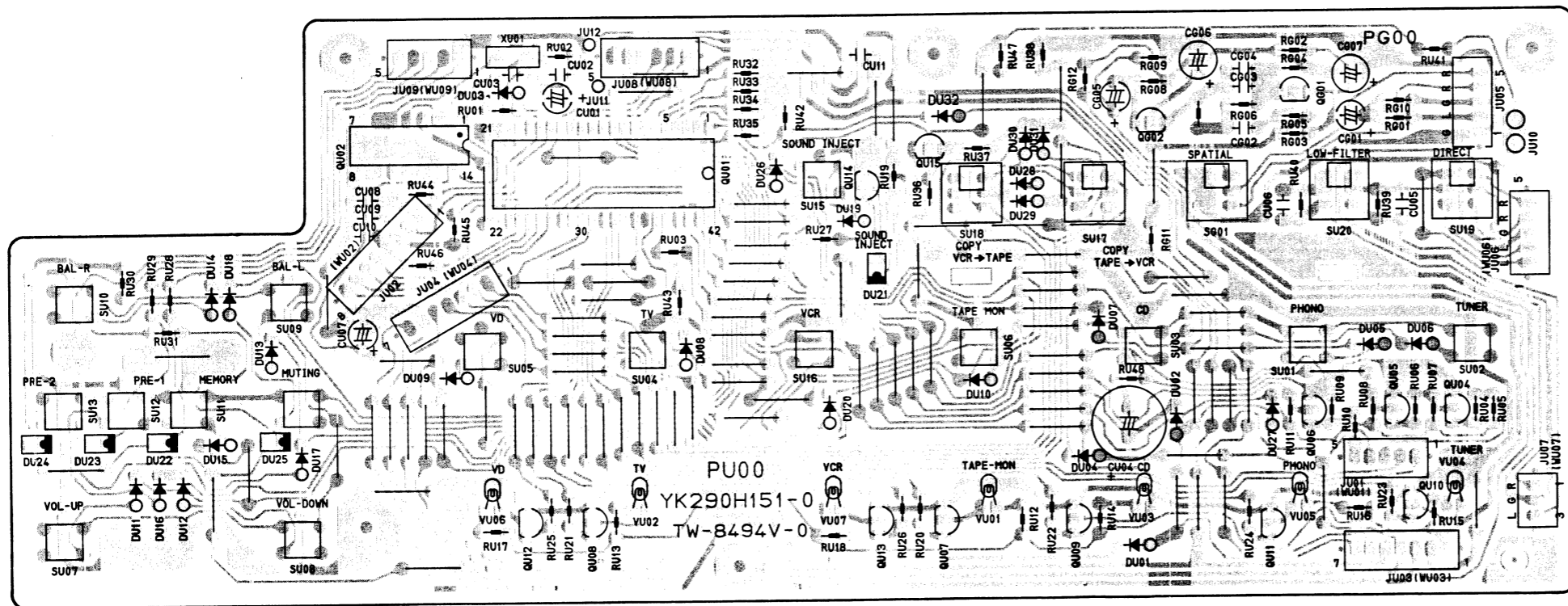
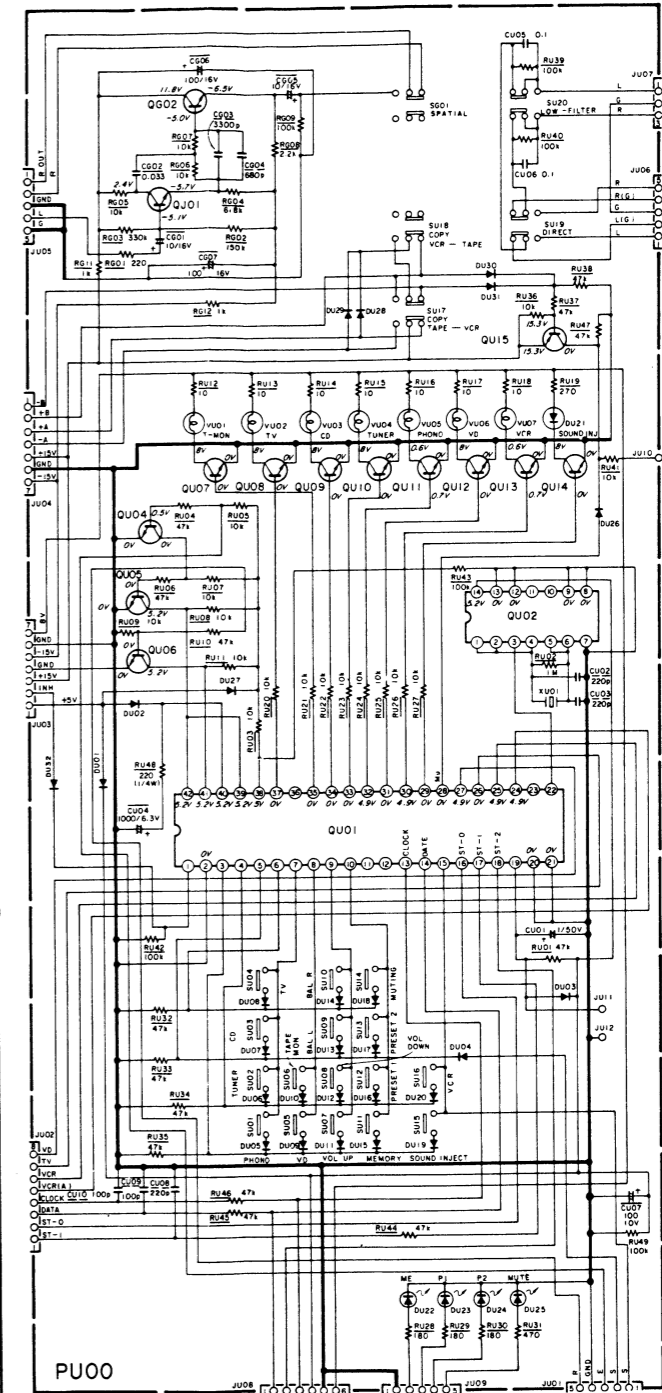

7.7 Main Amp. Assembly (P700) Schematic Diagram and Component Locations

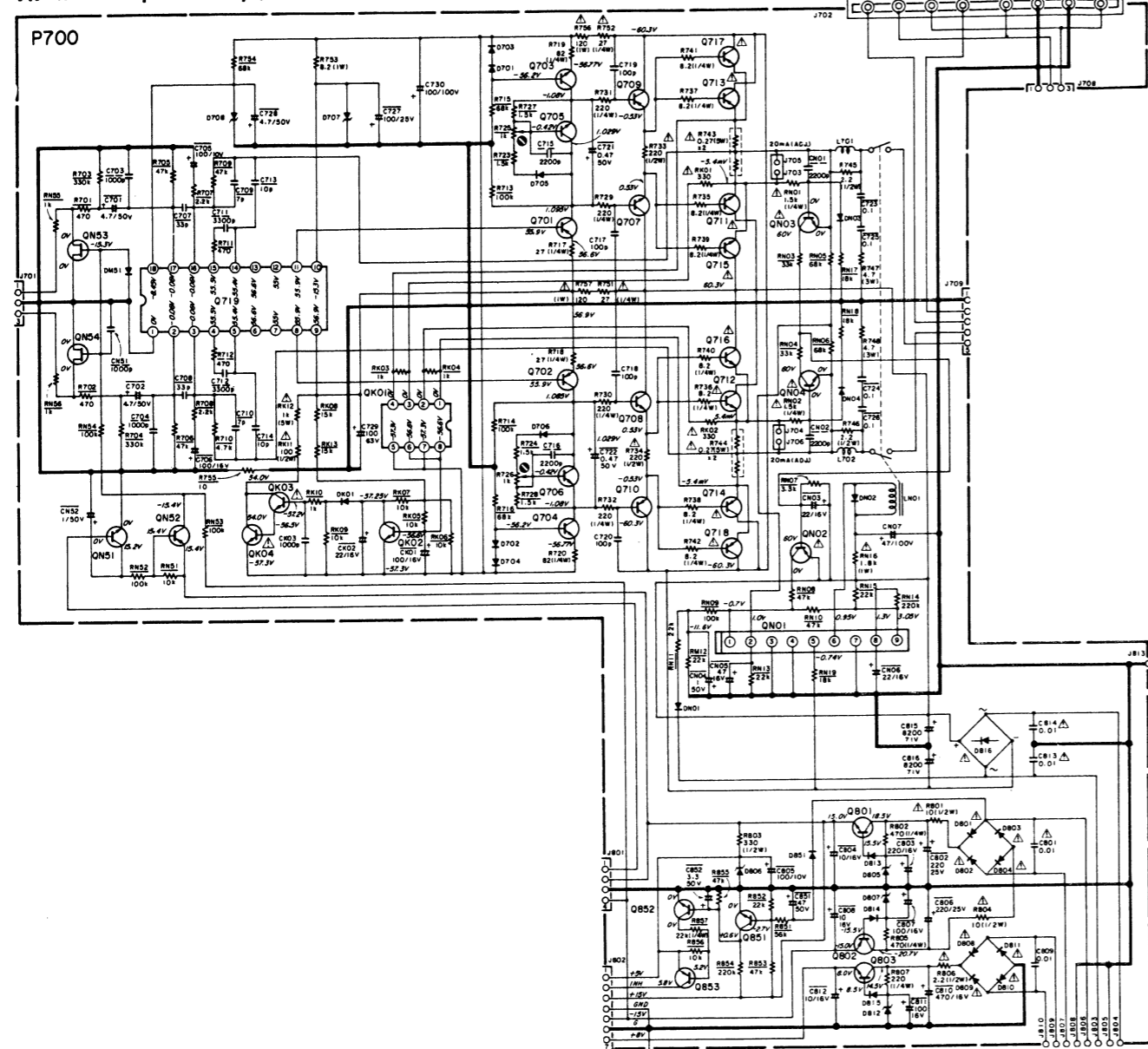

7.8 Volume Indicator Assembly (PU50) Schematic Diagram and Component Locations

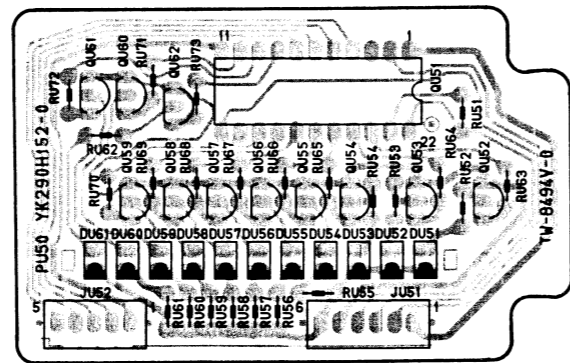
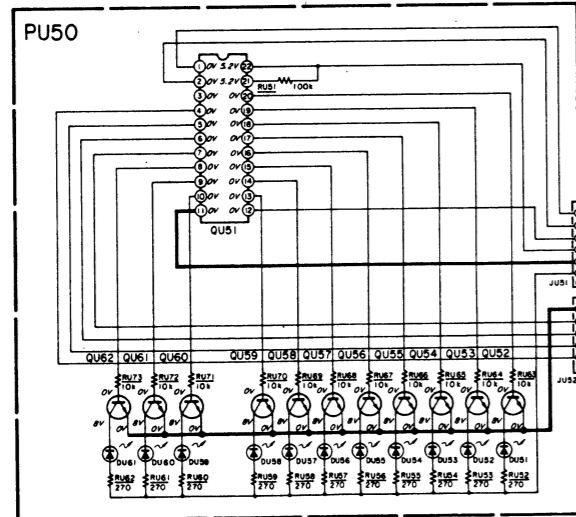

7.9 Speaker Switch Assembly (PT00) Schematic Diagram and Component Locations

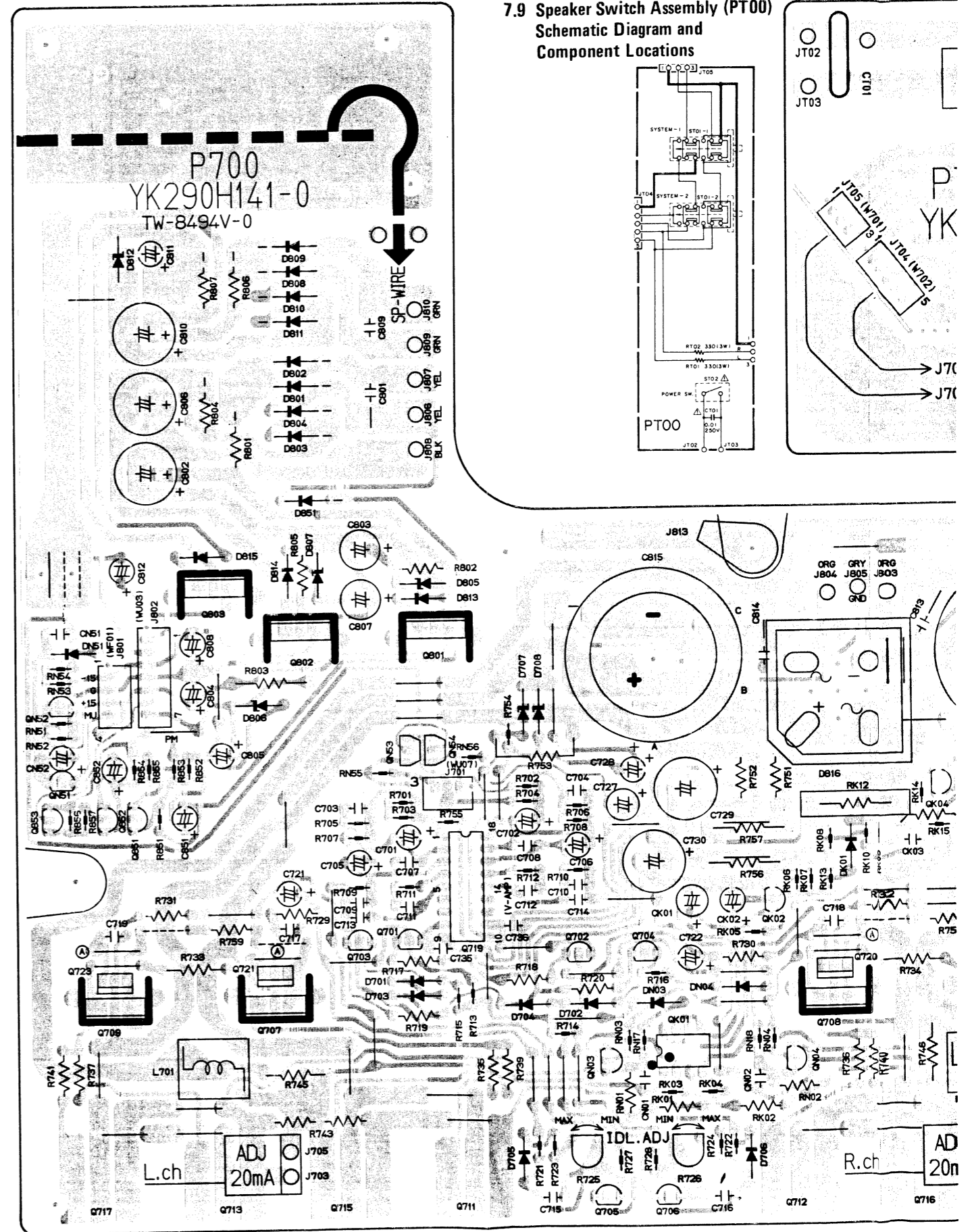

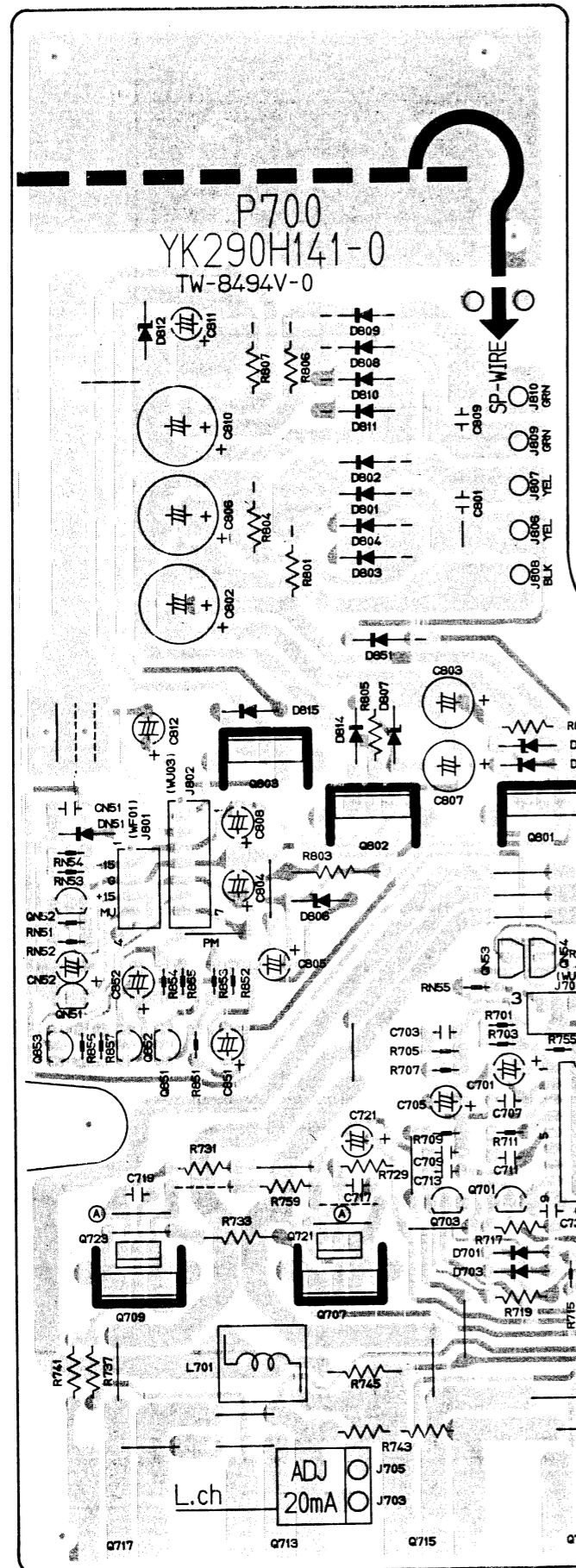
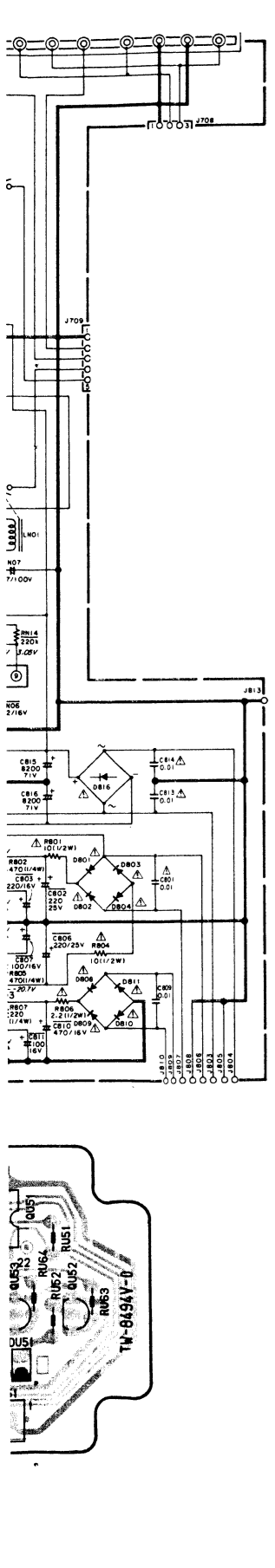

7.9 Speaker Switch Assembly (PT00)
Schematic Diagram and
Component Locations

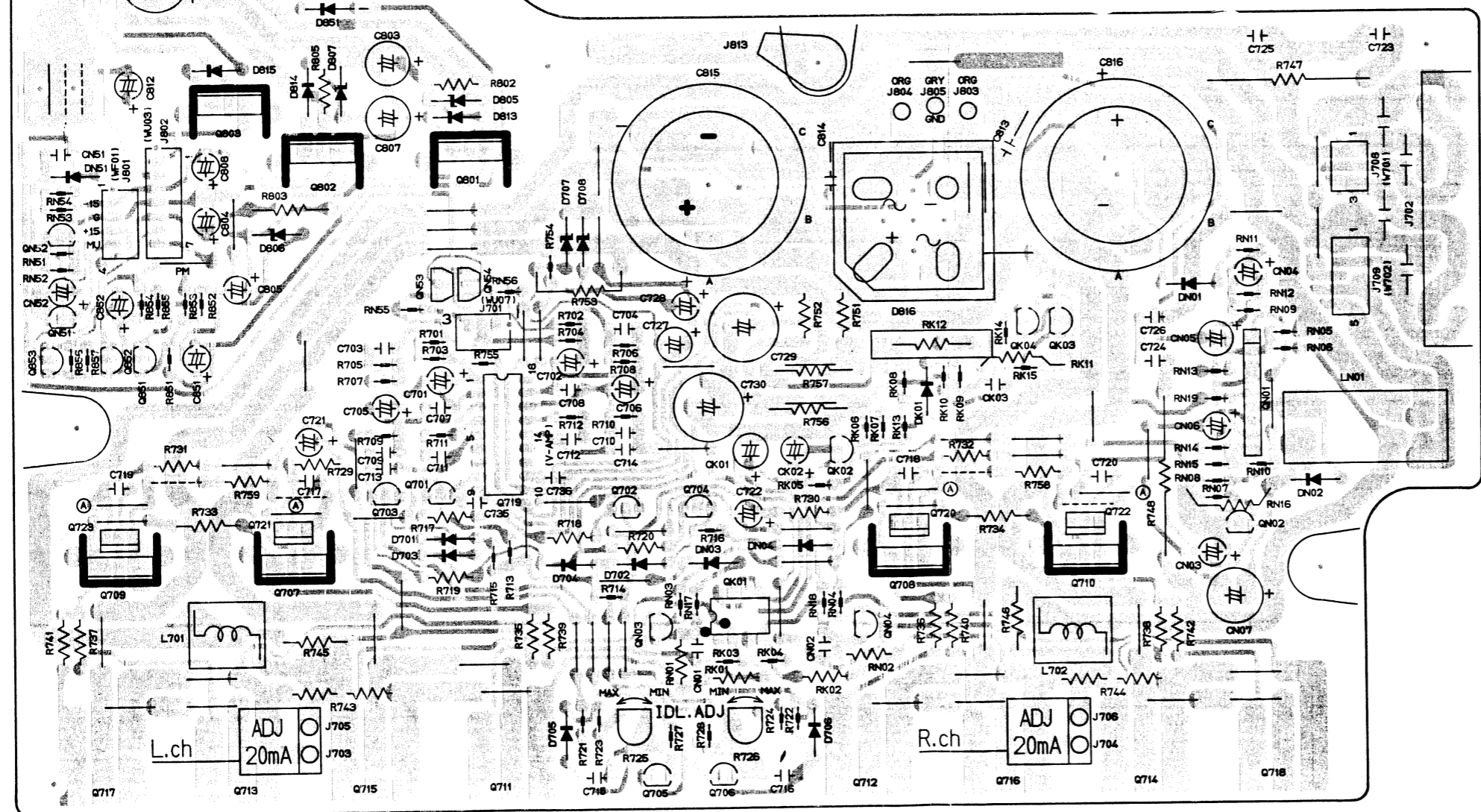
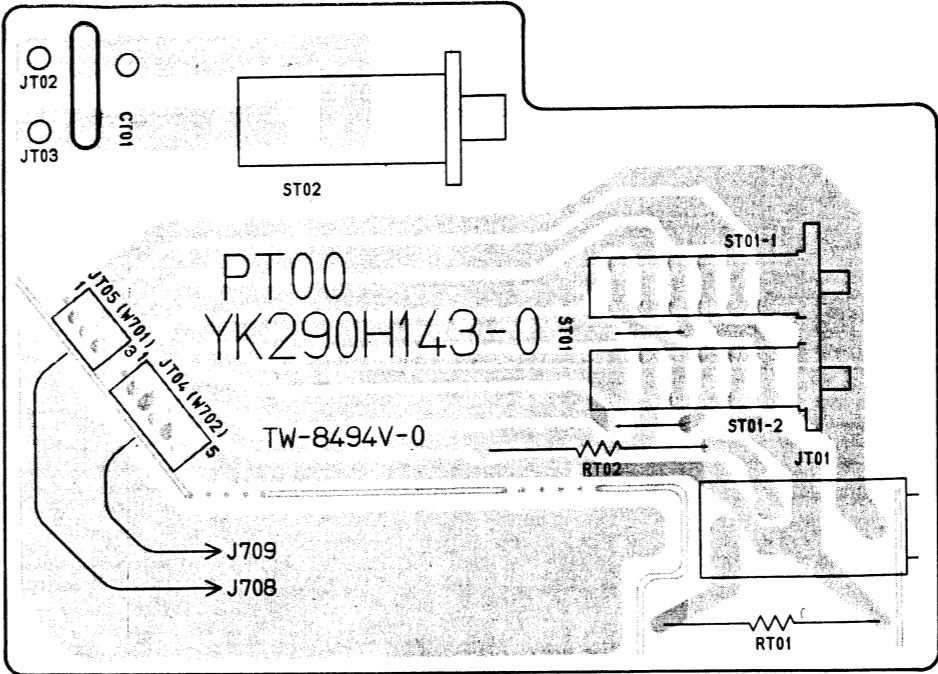
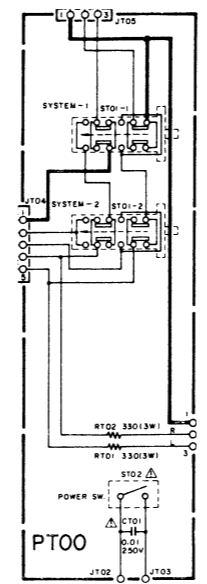

M2960

8. EXPLODED VIEW AND PARTS LIST

[C01-99] FRONT PANEL

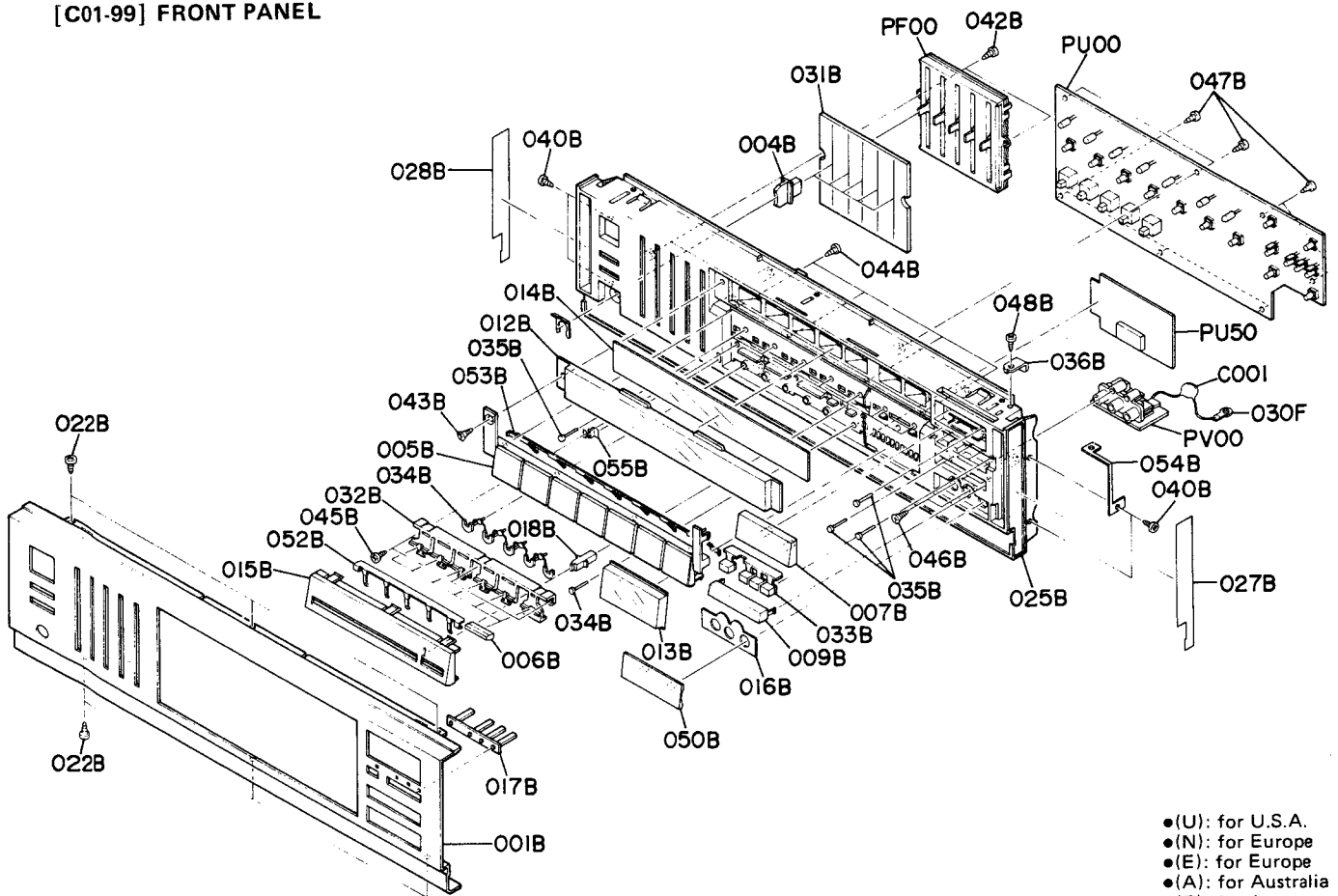

●(U): for U.S.A.
 ●(N): for Europe
 ●(E): for Europe
 ●(A): for Australia
 ●(F): for Japan

REF. DESIG.	PART NO.	DESCRIPTION
001B	290H248010	Front Panel, Gold (PM551) [U,N,E,A]
	290H248020	Front Panel, Black (PM551) [U,N,E,A,F]
	289H248010	Front Panel, Gold (PM451) [N,E,A]
	289H248020	Front Panel, Black (PM451) [N,E,A,F]
004B	289H154010	Knob, Equalizer; Gold
	289H154210	Knob, Equalizer; Black
005B	289H270030	Button, Function K; Gold
	289H270130	Button, Function K; Black
006B	289H270020	Button, Push; Gold
	289H270120	Button, Push; Black
007B	471H270340	Button, Volume; Gold
	471H270640	Button, Volume; Black
008B	289H270010	Button, Push; Gold
	289H270110	Button, Push; Black
009B	289H154020	Knob, Balance; Gold
	289H154220	Knob, Balance; Black
012B	289H158010	Window, Function
013B	289H158020	Window, Volume Level; Gold
	290H158010	Window, Volume Level; Black
014B	289H265010	Indicator, Function; Gold
	290H265010	Indicator, Function; Black
015B	289H063010	Escutcheon, Copy; Gold
	289H063110	Escutcheon, Copy; Black
016B	289H063020	Escutcheon, 3P Jack; Gold
	289H063120	Escutcheon, 3P Jack; Black
017B	289H355010	Lens, Tuning/Memo

REF. DESIG.	PART NO.	DESCRIPTION
018B	289H355020	Lens, Sound Inject
022B	51280308B0	B.H. Tapped Screw B3 x 8
025B	289H105500	Chassis, Front K; Gold
	289H105010	Chassis, Front; Black
027B	289H063030	Escutcheon, (R)
028B	289H063040	Escutcheon, (L)
031B	289H303010	Mask, Equalizer Knob
032B	289H271010	Holder, Copy Button
033B	289H271020	Holder, Memo Button
034B	289H254020	Pin, Push Switch
035B	289H254010	Pin, Switch
036B	289H104020	Retainer, Front PWB
040B	51280308B0	B.H. Tapped Screw B3 x 8
042B	51280308B0	B.H. Tapped Screw B3 x 8
043B	51280308B0	B.H. Tapped Screw B3 x 8
044B	51280308B0	B.H. Tapped Screw B3 x 8
045B	51280308B0	B.H. Tapped Screw B3 x 8
046B	51280308B0	B.H. Tapped Screw B3 x 8
047B	51280308B0	B.H. Tapped Screw B3 x 8
048B	51280308B0	B.H. Tapped Screw B3 x 8
050B	288H053010	Cover, 3P Jack
052B	289H115010	Spring
053B	289H123010	Contact
054B	289H123020	Contact
055B	289H123030	Contact
030F	62041760W0	Lug
C001	DK18473310	Ceramic Cap. 0.047μF +80% -20%

M2961

[C02-99] LID (TOP/BOTTOM COVER)

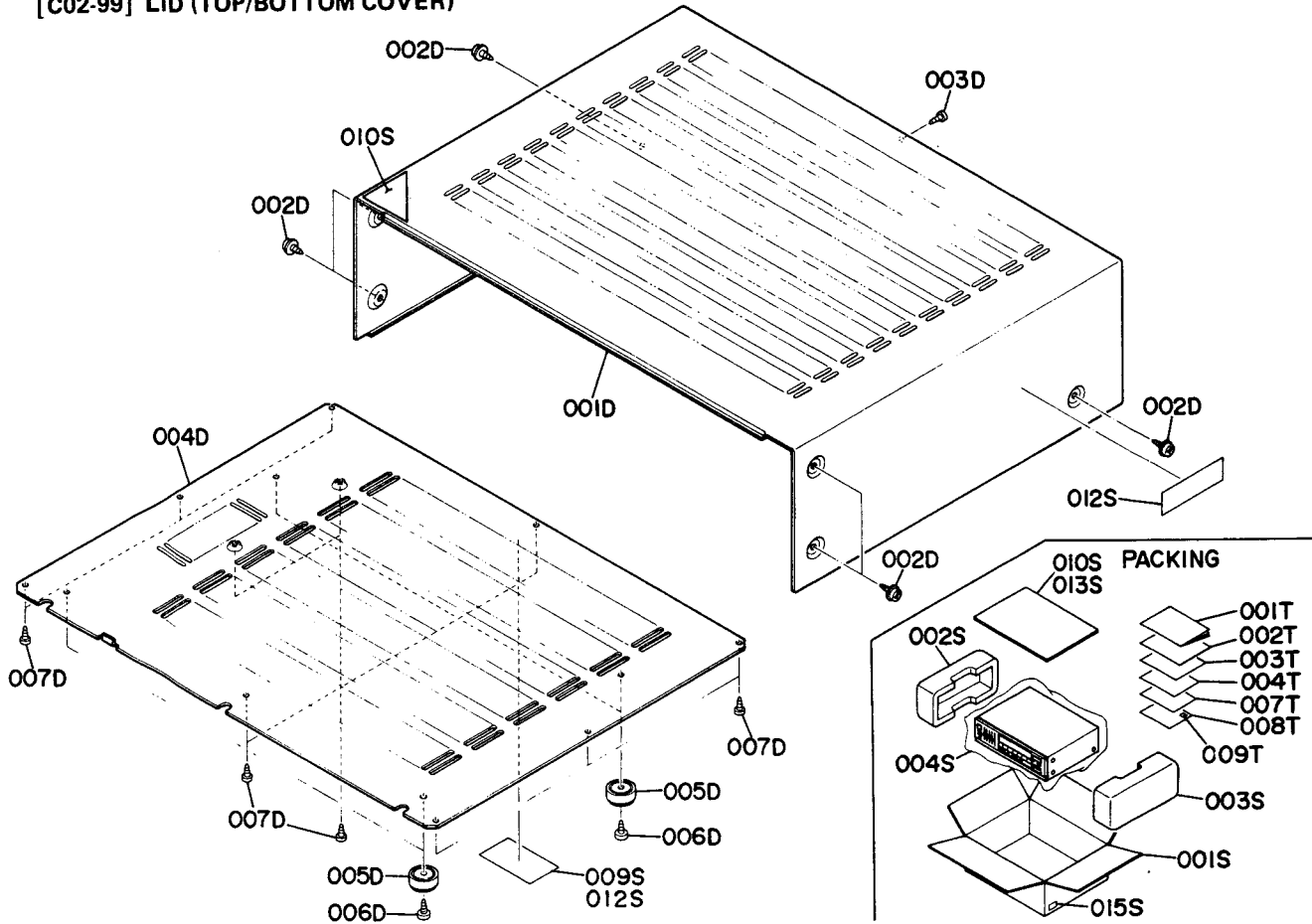

REF. DESIG.	PART NO.	DESCRIPTION
001D	289H257010	Lid, Top Cover; Gold
	289H257020	Lid, Top Cover; Black
002D	51260408U0	B.T. Screw B4 x 8
003D	51280308E0	B.H. Tapped Screw B3 x 8, Gold
	51280308U0	B.H. Tapped Screw B3 x 8, Black
004D	289H257030	Lid, Bottom Cover
005D	011T057010	Leg
006D	51280408B0	B.H. Tapped Screw B4 x 8
007D	51280308B0	B.H. Tapped Screw B3 x 8
009S	2911861110	Label, Caution [N,E,A]
010S	105H861010	Label, 3 Year [U]
012S	117H861010	Label, Caution [U]
001S	290H801020	PACKING Packing Case (PM551), [U]
	290H801010	Packing Case (PM551), [N,A,F]
	290H801040	Packing Case (PM551), [E]
	289H801010	Packing Case (PM451), [N,A,F]
	289H801020	Packing Case (PM451), [E]
002S	289H809010	Cushion, Left
003S	289H809020	Cushion, Right
004S	9014336220	Polyethylene Bag

REF. DESIG.	PART NO.	DESCRIPTION
010S	289H807010	Reinforcing (PM451), [E]
013S	289H807010	Reinforcing (PM551), [E]
015S	9526019010	Serial No. Card [U]
	9526019060	Serial No. Card [N]
	9526019050	Serial No. Card [E]
	9526019030	Serial No. Card [A]
	9526019040	Serial No. Card [F]
001T	290H851210	User Manual [U]
	290H851310	User Manual [N,E,A]
	290H851110	User Manual [F]
002T	290H851210	User Manual, Spec [U]
	290H851320	User Manual, Spec [N,E,A]
003T	290H856010	Circuit Diagram (PM551), [N,E]
	289H856010	Circuit Diagram (PM451), [N,E]
004T	103H854010	Warranty Card [U]
	9631000090	Warranty Card [E]
	9631000130	Warranty Card [F]
007T	128T854010	Warranty Card [F]
008T	9611000050	User's Card [F]
009T	9540000010	License [F]

[C03-99] REAR PANEL

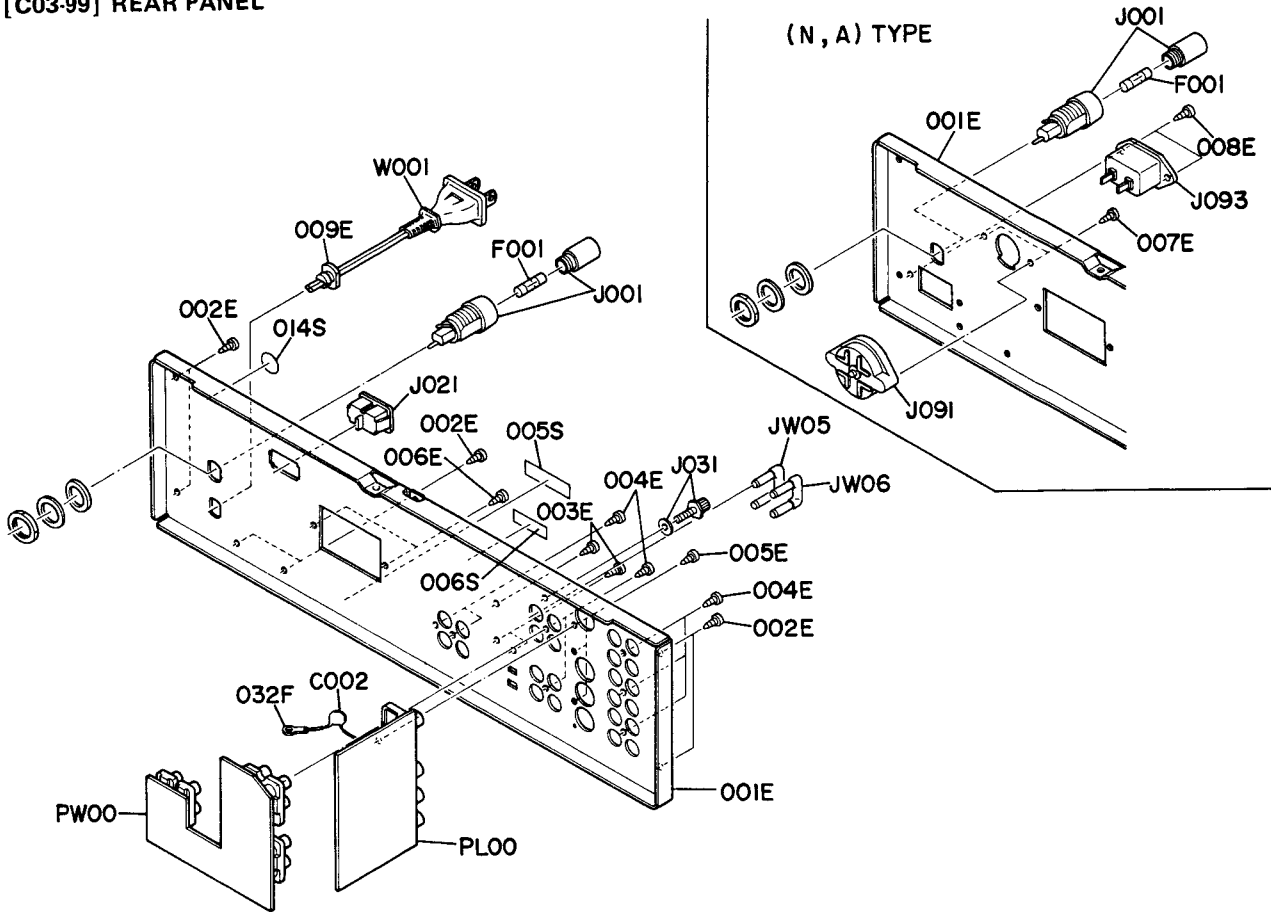

REF. DESIG.	PART NO.	DESCRIPTION
001E	290H250030	Rear Panel (PM551), [U]
	290H250010	Rear Panel (PM551), [N,A]
	290H250020	Rear Panel (PM551), [E]
	290H250040	Rear Panel (PM551), [F]
	289H250010	Rear Panel (PM451), [N,A]
	289H250020	Rear Panel (PM451), [E]
	289H250030	Rear Panel (PM451), [F]
002E	51280308B0	B.H. Tapped Screw B3 x 8
003E	51280308B0	B.H. Tapped Screw B3 x 8
004E	51280308B0	B.H. Tapped Screw B3 x 8
005E	51280308B0	B.H. Tapped Screw B3 x 8
006E	51280308B0	B.H. Tapped Screw B3 x 8
007E	51280308B0	B.H. Tapped Screw B3 x 8 [N,E,A]
008E	51280308B0	B.H. Tapped Screw B3 x 8 [N,A]
009E	1455259130	Bushing, AC Power Cord [U,E,F]
032F	62041760W0	Lug
005S	2112265010	Indicator, Serial No. [U]
	2112265110	Indicator, Serial No. [N,E,A,F]
006S	4581861010	Label, Made in Japan [N,E,A]
014S	9511101070	Label, UL [U]

REF. DESIG.	PART NO.	DESCRIPTION
△ F001	FS10600500	Fuse 6A 250V (PM551), [U]
	FS10250800	Fuse 2.5A 250V (PM551), [N,E,A]
	FS10600600	Fuse 6A 250V (PM551), [F]
	FS10140800	Fuse 1.4A 250V (PM451), [N,E,A]
△ J001	YJ08000300	Jack, Fuse Holder [U,F]
	YJ08000290	Jack, Fuse Holder [N,E,A]
△ J021	YJ04001180	Jack, AC Outlet [U,E,F]
J031	YL03010250	Terminal, GND
△ J091	BY05030040	Voltage Selector [N,A]
	BY05030050	Voltage Selector [E]
△ J093	YP04000610	Plug, AC Inlet [N,A]
JW05	YQ01000080	Shote Plug
JW06	YQ01000080	Shote Plug
△ W001	YC01900100	A.C. Power Cord [U]
	YC01900080	A.C. Power Cord [E,F]
C002	DK18473310	Ceramic Cap. 0.047μF +80% -20%

M2963

[C04-99] FRONT CHASSIS AND GENERAL PARTS

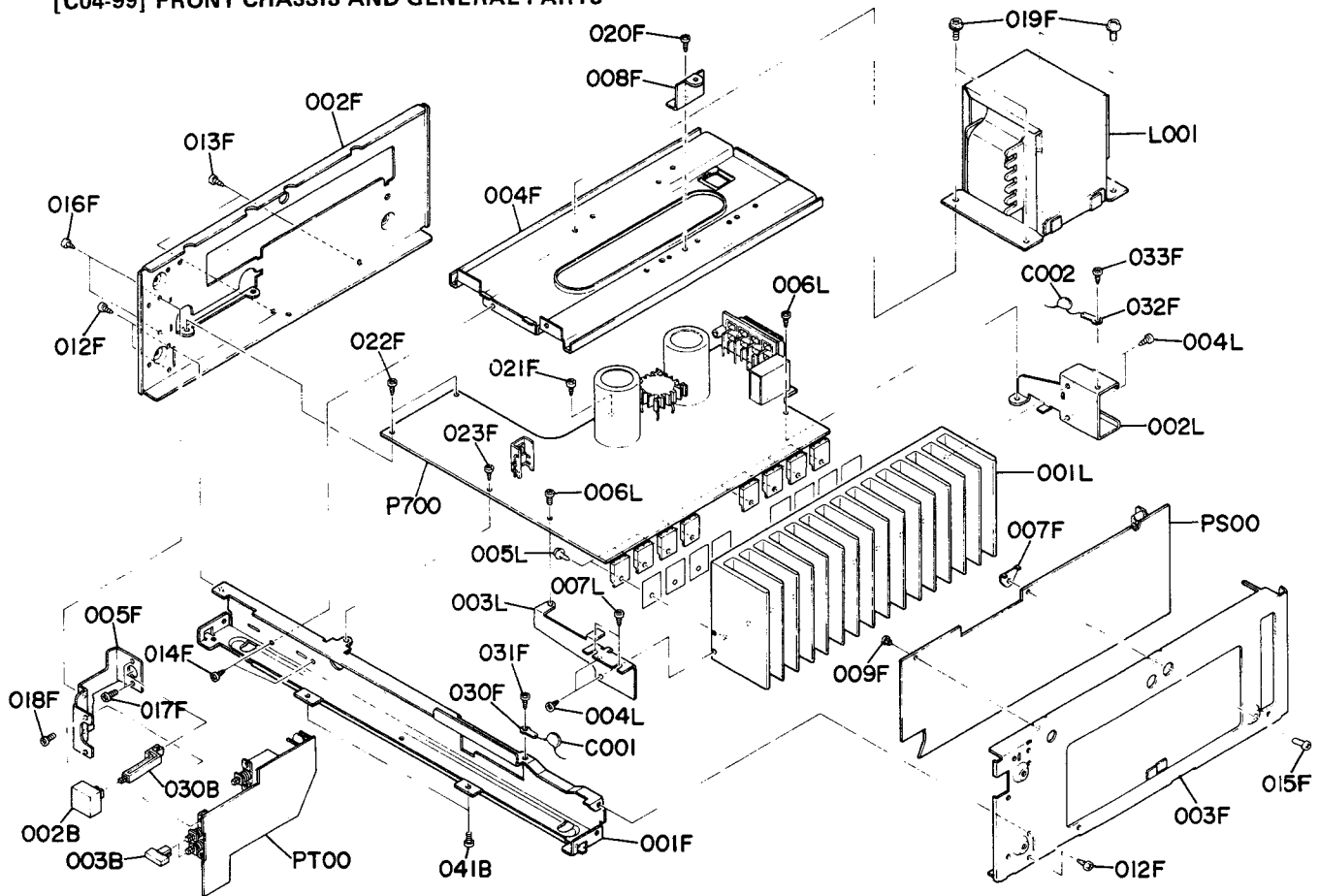

REF. DESIG.	PART NO.	DESCRIPTION
002B	158T270010	Button, Power Switch; Gold
	158T270110	Button, Power Switch; Black
003B	280H270010	Button, Speaker Switch; Gold
	280H270030	Button, Speaker Switch; Black
030B	289H121010	Link, Power Switch
041B	51280308B0	B.H. Tapped Screw B3 x 8
001F	289H126010	Stay, Front
002F	289H105020	Chassis, Side; (L)
003F	289H105030	Chassis, Side; (R)
004F	289H160010	Bracket, Power Transformer
005F	289H104010	Retainer, Power Switch
007F	270H011010	Nut, GND
008F	284H104020	Retainer, Main PWB
009F	2276005050	Clamper
012F	51280308B0	B.H. Tapped Screw B3 x 8
013F	51280308B0	B.H. Tapped Screw B3 x 8
014F	51280308B0	B.H. Tapped Screw B3 x 8
015F	51100308A0	B.H.M. Screw B3 x 8
016F	51280308B0	B.H. Tapped Screw B3 x 8
017F	51100308A0	B.H.M. Screw B3 x 8
018F	51100308A0	B.H.M. Screw B3 x 8
019F	52040408A0	H. Head Bolt, S.F. H4 x 8
020F	51500308B0	F.H. Taptite Screw F3 x 8
021F	51280308B0	B.H. Tapped Screw B3 x 8
022F	51280308B0	B.H. Tapped Screw B3 x 8
023F	51280308B0	B.H. Tapped Screw B3 x 8

REF. DESIG.	PART NO.	DESCRIPTION
030F	62041760W0	Lug
031F	51280308B0	B.H. Tapped Screw B3 x 8
032F	62041760W0	Lug
033F	51280308B0	B.H. Tapped Screw B3 x 8
001L	290H267010	Heatsink, Main (PM551)
	289H267010	Heatsink, Main (PM451)
002L	284H104010	Retainer, Rear
003L	284H104020	Retainer, Front
004L	51280308B0	B.H. Tapped Screw B3 x 8
005L	51780312B0	Fin Neck B.T Screw B3 x 12
006L	51100308A0	B.H.M. Screw B3 x 8
007L	51280308B0	B.H. Tapped Screw B3 x 8
Δ L001	TS19624020	Power Transformer (PM551), [U]
	TS19624030	Power Transformer (PM551), [N,A]
	TS19624040	Power Transformer (PM551), [E]
	TS19624010	Power Transformer (PM551), [F]
	TS17631010	Power Transformer (PM451), [N,A]
	TS17631030	Power Transformer (PM451), [E]
C001	DK18473310	Ceramic Cap. 0.047μF +80% -20%
C002	DK18473310	Ceramic Cap. 0.047μF +80% -20%

9. ELECTRICAL PARTS LIST

- (U): for U.S.A.
- (N): for Europe
- (E): for Europe
- (A): for Australia
- (F): for Japan

ASSIGNMENT OF COMMON PARTS CODES.

RESISTOR

- R***:** (1) GD05 --- 140, Carbon film fixed resistor, ±5%, 1/4W
R*:** (2) GD05 --- 160, Carbon film fixed resistor, ±5%, 1/6W

① — Resistance value

Examples

- ① Resistance value
- | | | | |
|------------|------------|-------------|--------------|
| 0.1Ω...001 | 10Ω...100 | 1kΩ...102 | 100kΩ...104 |
| 0.5Ω...005 | 18Ω...180 | 2.7kΩ...272 | 680kΩ...684 |
| 1Ω...010 | 100Ω...101 | 10kΩ...103 | 1MkΩ...105 |
| 6.8Ω...068 | 390Ω...391 | 22kΩ...223 | 4.7MkΩ...475 |

(Note) Please distinguish 1/4W from 1/6W by the shape of parts used actually.

C***: CERAMIC CAP.

- (1) DD1 --- 370, Ceramic condenser
 Disc type
 Temp. coeff. P350 ~ N1000, 50V

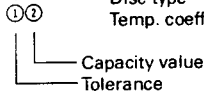

Examples

- ① Tolerance (Capacity deviation)
- | |
|-------------|
| ±0.25pF...0 |
| ±0.5pF...1 |
| ±5%...5 |

* Tolerance of COMMON PARTS handled here are as follows:

- | |
|-----------------------|
| 0.5pF ~ 5pF...±0.25pF |
| 6pF ~ 10pF...±0.5pF |
| 12pF ~ 560pF...±5% |

- ② Capacity value
- | | | |
|-------------|------------|-------------|
| 0.5pF...005 | 3pF...030 | 100pF...101 |
| 1pF...010 | 10pF...100 | 220pF...221 |
| 1.5pF...015 | 47pF...470 | 560pF...561 |

C***: CERAMIC CAP.

- (1) DK16 --- 300, High dielectric constant ceramic condenser
 Disc type
 Temp. chara. 2B4, 50V

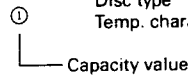

Example

- ② Capacity value
- | | | |
|-------------|--------------|---------------|
| 100pF...101 | 1000pF...102 | 10000pF...103 |
| 470pF...471 | 2200pF...222 | |

C***: ELECTROLY CAP. (⚡), FILM CAP. (≡)

- (1) EA --- 10, Electrolytic condenser
 One-way lead type, Tolerance ±20%

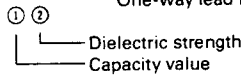

Examples

- ① Capacity value
- | | | |
|--------------|-------------|--------------|
| 0.1μF...104 | 4.7μF...475 | 100μF...107 |
| 0.33μF...334 | 10μF...106 | 330μF...337 |
| 1μF...105 | 22μF...226 | 1100μF...108 |
| | | 2200μF...228 |

- ② Working voltage
- | | |
|------------|-----------|
| 6.3V...006 | 25V...025 |
| 10V...010 | 35V...035 |
| 16V...016 | 50V...050 |

- (2) DF15 --- 350, Plastic film condenser
 One-way type, Mylar ±5% 50V

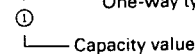

Examples

- ① Capacity value
- | | |
|------------------------|--------------|
| 0.001μF (1000pF)...102 | 0.1μF...104 |
| 0.0018μF...182 | 0.56μF...564 |
| 0.01μF...103 | 1μF...105 |
| 0.015μF...153 | |

REF. DESIG.	PART NO.	DESCRIPTION
P700	YK290H1410 ZZ290H1410 ZZ289H8410	P700-MAIN AMP CIRCUIT BOARD P.W. Board, Main Amp P.W. Board Assembly (PM551) P.W. Board Assembly (PM451)
CK03 CN07	DK18102310 EA47606310	P700-CAPACITORS Ceramic 1000pF 50V (PM551) Elect 47μF 63V
C717 C718 C719 C720 C729	DD15101560 DD15101560 DD15101560 DD15101560 EA10710010	Ceramic 100pF ±5% 500V Ceramic 100pF ±5% 500V Ceramic 100pF ±5% 500V Ceramic 100pF ±5% 500V Elect 100μF 100V (PM551)
C730	EA10706310 EA10710010 EA10706310	Elect 100μF 63V (PM451) Elect 100μF 100V (PM551) Elect 100μF 63V (PM451)
C801 C809 Δ C813 Δ C814 C815 C816	DK18103560 DK18103310 DK18103560 DK18103560 EB82807110 EB68806320 EB82807110 EB68806320	Ceramic 0.01μF +80% -20% 500V Ceramic 0.01μF +80% -20% 50V Ceramic 0.01μF +80% -20% 500V Ceramic 0.01μF +80% -20% 500V Elect 8200μF 71V (PM551) Elect 6800μF 63V (PM451) Elect 8200μF 71V (PM551) Elect 6800μF 63V (PM451)
Δ RK01 Δ RK02 Δ RK11 Δ RK12	NH05331140 NH05331140 GG05101120 GP05102750	330Ω ±5% ¼W, Fusible (PM551) 330Ω ±5% ¼W, Fusible (PM551) 100Ω ±5% ¼W (PM551) 1KΩ ±5% 5W (PM551)
Δ RN01 Δ RN02 Δ RN16	NF02152140 NH05681140 NF02152140 NF05681140 GA05182010	1.5KΩ ±2% ¼W, Fuse (PM551) 680Ω ±5% ¼W, Fusible (PM451) 1.5KΩ ±2% ¼W, Fuse (PM551) 680Ω ±5% ¼W, Fusible (PM451) 1.8KΩ ±5% 1W
R717 R718 R719 R720 R725 R726 R729 R730 R731 R732	GG05470140 GG05470140 GG05820140 GG05820140 RA01020600 RA01020600 GG05221140 GG05221140 GG05221140 GG05221140 GG05221140	47Ω ±5% ¼W 47Ω ±5% ¼W 82Ω ±5% ¼W 82Ω ±5% ¼W 1KΩ(B), Trimming; Idle Current 1KΩ(B), Trimming; Idle Current 220Ω ±5% ¼W 220Ω ±5% ¼W 220Ω ±5% ¼W 220Ω ±5% ¼W 220Ω ±5% ¼W
Δ R733 Δ R734 R735 ? R738 R739 R740 R741 R742 Δ R743	NH05221120 NH05221120 GG05068140 GG05082140 GG05082140 GG05082140 GG05082140 GG05082140 BW10000030 BW10000040	220Ω ±5% ¼W, Fusible 220Ω ±5% ¼W, Fusible 6.8Ω ±5% ¼W 8.2Ω ±5% ¼W (PM551) 8.2Ω ±5% ¼W (PM551) 8.2Ω ±5% ¼W (PM551) 8.2Ω ±5% ¼W (PM551) 8.2Ω ±5% ¼W (PM551) 0.27Ωx2 ±10% 5W, Composite(PM551) 0.27Ωx2 ±10% 3W, Composite(PM451)
Δ R744 R745 R746 R747	BW10000030 BW10000040 GG05022120 GG05022120 GA05047030	0.27Ωx2 ±10% 5W, Composite(PM551) 0.27Ωx2 ±10% 5W, Composite(PM451) 2.2Ω ±5% ¼W 2.2Ω ±5% ¼W 4.7Ω ±5% 3W

M2965

REF. DESIG.	PART NO.	DESCRIPTION
R748	GA05047030	4.7Ω ±5% 3W
△ R751	NH05270140	27Ω ±5% ¼W, Fusible (PM551)
	NH05101140	100Ω ±5% ¼W, Fusible (PM451)
△ R752	NH05270140	27Ω ±5% ¼W, Fusible (PM551)
	NH05101140	100Ω ±5% ¼W, Fusible (PM451)
R753	GA05822010	8.2KΩ ±5% 1W
△ R756	GA05121010	120Ω ±5% 1W (PM551)
△ R757	GA05121010	120Ω ±5% 1W (PM551)
△ R801	NH05100120	10Ω ±5% ¼W, Fusible
R802	GG05471140	470Ω ±5% ¼W
R803	GA05151010	150Ω ±5% 1W
△ R804	NH05100120	10Ω ±5% ¼W, Fusible
R805	GG05471140	470Ω ±5% ¼W
△ R806	NH05022120	2.2Ω ±5% ¼W, Fusible
R807	GG05221140	220Ω ±5% ¼W
P700-SEMICONDUCTORS		
DK01	HD20001000	Diode 1S2473 or 1S1555 etc. (PM551)
DN01	HD20022030	Diode DSF10C
DN02	HD20022030	Diode DSF10C
DN03	HD20003210	Diode 1S2471
DN04	HD20003210	Diode 1S2471
DN51	HD20001000	Diode 1S2473 or 1S1555 etc.
D701	HD20001000	Diode 1S2473 or 1S1555 etc.
D706		
D707	HD30012020	Zener MA1150M
D708	HD30024020	Zener MA1082M
△ D801	HD20015030	Diode DS135D
△ D802	HD20015030	Diode DS135D
△ D803	HD20015030	Diode DS135D
△ D804	HD20015030	Diode DS135D
D805	HD30020020	Zener MA1160M
D806	HD30005020	Zener MA1056M
D807	HD30020020	Zener MA1160M
△ D808	HD20015030	Diode DS135D
△ D809	HD20015030	Diode DS135D
△ D810	HD20015030	Diode DS135D
△ D811	HD20015030	Diode DS135D
D812	HD30007020	Zener MA1091M
D813	HD20001000	Diode 1S2473 or 1S1555 etc.
D814	HD20001000	Diode 1S2473 or 1S1555 etc.
D815	HD20001000	Diode 1S2473 or 1S1555 etc.
△ D816	HE20012290	Diode D5FB20 (PM551)
	HE20009290	Diode S5VB20 (PM451)
D851	HD20015030	Diode DS135D
QK01	HW10004320	Photo Unit PC-827 (PM551)
QK02	HT309452B0	Transistor 2SC945(Q, R) (PM551)
△ QK03	HT325511B0	Transistor 2SC2551 (PM551)
△ QK04	HT325511B0	Transistor 2SC2551 (PM551)
QN01	HC10042050	IC TA7317P
△ QN02	HT109701A0	Transistor 2SA970(GR)
△ QN03	HT322401A0	Transistor 2SC2240(GR)
△ QN04	HT322401A0	Transistor 2SC2240(GR)
QN51	HT309452B0	Transistor 2SC945(Q, R)
QN52	HT111752D0	Transistor 2SA1175(EF, FF)
QN53	HF203722A0	F.E.T. 2SK372(GR, BL)
QN54	HF203722A0	F.E.T. 2SK372(GR, BL)

REF. DESIG.	PART NO.	DESCRIPTION
Q701	HT112082A0	Transistor 2SA1208(R, S)
Q702	HT112082A0	Transistor 2SA1208(R, S)
Q703	HT329102A0	Transistor 2SC2910(R, S)
Q704	HT329102A0	Transistor 2SC2910(R, S)
Q705	HT309452B0	Transistor 2SC945(Q, R)
Q706	HT309452B0	Transistor 2SC945(Q, R)
Q707	HT332982D0	Transistor 2SC3298(O, Y)
Q708	HT332982D0	Transistor 2SC3298(O, Y)
Q709	HT113062D0	Transistor 2SA1306(O, Y)
Q710	HT113062D0	Transistor 2SA1306(O, Y)
△ Q711	HT331822A0	Transistor 2SC3182(R, O)
△ Q712	HT331822A0	Transistor 2SC3182(R, O)
△ Q713	HT112652A0	Transistor 2SA1265(R, O)
△ Q714	HT112652A0	Transistor 2SA1265(R, O)
△ Q715	HT331822A0	Transistor 2SC3182(R, O) (PM551)
△ Q716	HT331822A0	Transistor 2SC3182(R, O) (PM551)
△ Q717	HT112652A0	Transistor 2SA1265(R, O) (PM551)
△ Q718	HT112652A0	Transistor 2SA1265(R, O) (PM551)
Q719	HC10066020	IC AN7062P
Q801	HT332982D0	Transistor 2SC3298(O, Y)
Q802	HT113062D0	Transistor 2SA1306(O, Y)
Q803	HT332982D0	Transistor 2SC3298(O, Y)
Q851	HT309452B0	Transistor 2SC945(Q, R)
Q852	HT309452B0	Transistor 2SC945(Q, R)
Q853	HT111752D0	Transistor 2SA1175(EF, FF)
P700-MISCELLANEOUS		
J701	YJ06002430	Jack, 3P
J702	YT03080020	Terminal, 8P; Speaker
J801	YJ06002440	Jack, 4P
J802	YJ06002460	Jack, 7P
J813	YL01010110	Terminal, GND
LN01	LY20240190	Relay, Speaker Protector (PM551)
	LY20240260	Relay, Speaker Protector (PM451)
L701	LL23905120	Choke Coil 3.9mH
L702	LL23905120	Choke Coil 3.9mH
PF00-GRAPHIC EQUALIZER CIRCUIT BOARD		
PF00	YK290H1440	P.W. Board, Graphic Equalizer
	ZZ290H1440	P.W. Board Assembly
PF00-RESISTORS		
△ RF19	GG05181140	180Ω ±5% ¼W
△ RF20	GG05181140	180Ω ±5% ¼W
RF21	RY01040050	100KΩ(B), Variable; Band GEO
PF00-SEMICONDUCTORS		
QF01	HC10008090	IC NJM4558DD
QF02	HC10036200	IC M5227P
QF03	HC10036200	IC M5227P
PF00-MISCELLANEOUS		
JF01	YJ06002440	Jack, 4P
JF02	YJ06002390	Jack, 5P
JF03	YJ06002460	Jack, 7P
JF04	YJ06002460	Jack, 7P
WF01	YU04140260	Jumper Lead, 4P

REF. DESIG.	PART NO.	DESCRIPTION
PL00	YK290H1420 ZZ290H1420 ZZ290H8420	PL00-VISUAL SELECTOR CIRCUIT BOARD P.W. Board, Visual Selector P.W. Board Assembly [U,C,E,F] P.W. Board Assembly [N,A]
RL31 RL32	NK05221010 NK05221010	PL00-RESISTORS 220Ω ±5% 1W, Metal 220Ω ±5% 1W, Metal
DL01 DL02 DL03	HD30004020 HD30004020 HD20001000	PL00-SEMICONDUCTORS Zener MA1051M Zener MA1051M Diode 1S2473 or 1S155 etc.
QL01 QL02 QL03	HC406603C0 HT111752D0 HT327852D0	IC LC4066BH Transistor 2SA1175(FF, EF) Transistor 2SC2785(FF, EF)
QL08 QL09 QL10 QL11	HT111752D0 HT111752D0 HT111752D0 HT111752D0	Transistor 2SA1175(FF, EF) Transistor 2SA1175(FF, EF) Transistor 2SA1175(FF, EF)
JL01 JL02	YT02040560 YT02040340 YJ07001760	PL00-MISCELLANEOUS Terminal, 4P; Video IN [U,C,E,F] Terminal, 4P; Video IN [N,A] Jack, 6P
PS00	YK290H1530 ZZ290H1530	PS00-INPUT SELECTOR CIRCUIT BOARD P.W. Board, Input Selector P.W. Board Assembly
CS18 CS19 CS20 CS21 CS22 CS23	DK18103310 DK18103310 DK18103310 DK18103310 DK18103310 DK18103310	PS00-CAPACITORS Ceramic 0.01μF +80% -20% 50V Ceramic 0.01μF +80% -20% 50V Ceramic 0.01μF +80% -20% 50V Ceramic 0.01μF +80% -20% 50V Ceramic 0.01μF +80% -20% 50V Ceramic 0.01μF +80% -20% 50V
C407 C408	DK18102310 DK18102310	Ceramic 1000pF +80% -20% 50V Ceramic 1000pF +80% -20% 50V
ΔRS37 ΔRS38	GG05181140 GG05181140	PS00-RESISTORS 180Ω ±5% ¼W 180Ω ±5% ¼W
ΔR415 ΔR416	GG05181140 GG05181140	180Ω ±5% ¼W 180Ω ±5% ¼W
QS01 QS02 QS03 QS04 QS05 QS06 QS07 QS08 QS09 QS10	HC10117050 HC10150030 HC10118050 HC10008090 HC10150030 HC10150030 HC10008090 HT30001000 HT10001000 HT10001000	PS00-SEMICONDUCTORS IC TC9163N IC LC4966 IC TC9176P IC NJM4558DD IC LC4966 IC LC4966 IC NJM4558DD Transistor 2SC536SP(F, G) etc. Transistor 2SA608SP(F, G) etc. Transistor 2SA608SP(F, G) etc.
Q401	HC10008090	IC NJM4558DD

REF. DESIG.	PART NO.	DESCRIPTION
JS01 JS02 JS03 JS05 JS06 JS07 JS08 JS09 JS10 JS11 JS12	YT02040610 YT02040500 YT02040500 YJ06002450 YJ06002450 YJ06002440 YJ06002430 YJ06002430 YJ06002460 YJ06002270 YL01010110	PS00-MISCELLANEOUS Terminal, 4P; Phone/CD Terminal, 4P; Tuner/TV Terminal, 4P, Tape IN/OUT Jack, 6P Jack, 6P Jack, 4P Jack, 3P Jack, 3P Jack, 7P Jack, 8P Terminal, Earth
WL01 WS02	YU06160260 YU03080260	Jumper Lead, 6P Jumper Lead, 3P
PT00	YK290H1430 ZZ290H1430 ZZ290H2430	PT00-SPEAKER SWITCH CIRCUIT BOARD P.W. Board, Speaker Switch P.W. Board Assembly (BLACK) P.W. Board Assembly (GOLD)
ΔCT01	DK18103840 DK18103850	PT00-CAPACITOR Ceramic 0.01μF 250V Ceramic 0.01μF 250V [F]
RT01 RT02	GA05331030 GA05331030	PT00-RESISTORS 330Ω ±5% 3W 330Ω ±5% 3W
JT01	YJ01002080 YJ01001790	PT00-MISCELLANEOUS Jack, Phone (Black) Jack, Phone (Grey)
ST01 ΔST02	SP04020480 SP01010960	Push Switch, Speaker Push Switch, Power
W701 W702	YU03280240 YU05300240	Jumper Lead, 3P Jumper Lead, 5P
PU00	YK290H1510 ZZ290H1510	PU00-FRONT SWITCH CIRCUIT BOARD P.W. Board, Front Switch P.W. Board Assembly
CG02 CU01 CU05 CU06	DF16333350 EJ10505010 DF16104350 DF16104350	PU00-CAPACITORS Film 0.033μF ±10% 50V Elect 1μF 50V Film 0.1μF ±10% 50V Film 0.1μF ±10% 50V
DU01 ? DU20 DU21 DU22 DU23 DU24 DU25 DU26 ? DU32	HD20015210 HD20015210 H110038030 H110052030 H110052030 H110052030 H110053030 HD20015210 HD20015210 DU32	PU00-SEMICONDUCTORS Diode 1SS133 L.E.D. SLP-281F L.E.D. SLP-274B L.E.D. SLP-274B L.E.D. SLP-274B L.E.D. SLP-174B Diode 1SS133

M2967

REF. DESIG.	PART NO.	DESCRIPTION
QG01	HT327852D0	Transistor 2SC2785(FF, EF)
QG02	HT327852D0	Transistor 2SC2785(FF, EF)
QU01	HC10169030	IC LM6502C
QU02	HC401100B0	IC 4011
QU04	HT30001000	Transistor 2SC536SP(F, G) etc.
QU05	HT30001000	Transistor 2SC536SP(F, G) etc.
QU06	HT30001000	Transistor 2SC536SP(F, G) etc.
QU07		
?	HT327852D0	Transistor 2SC2785(FF, EF)
QU14		
QU15	HT111752D0	Transistor 2SA1175(FF, EF)
		PU00-MISCELLANEOUS
JU05	YJ06002390	Jack, 5P
SG01	SP02011270	Push Switch, SPH
SU01		
?	SP01011000	Push Switch, KHH
SU16		
SU17	SP02011270	Push Switch, SPH
SU18	SP02011270	Push Switch, SPH
SU19	SP02011270	Push Switch, SPH
SU20	SP02011270	Push Switch, SPH
VU01		
?	IN10080650	Lamp 50mA 8V
VU07		
WU01	YU05400260	Jumper Lead, 5P
WU02	YU08140260	Jumper Lead, 8P
WU03	YU07120260	Jumper Lead, 7P
WU04	YU07140260	Jumper Lead, 7P
WU06	YU05090260	Jumper Lead, 5P
WU07	YU03180260	Jumper Lead, 3P
WU08	YU06080260	Jumper Lead, 6P
WU09	YU05080260	Jumper Lead, 5P
XU01	FQ04003010	Seramic Vibrator, CSB-400P
		PU50-VOLUME INDICATOR CIRCUIT BOARD
PU50	YK290H1520	P.W. Board, Volume Indicator
	ZZ290H1520	P.W. Board Assembly
DU51		
?	HI10038030	L.E.D. SLP-281F, Green
DU61		
QU51	HC10001260	IC MSM59371RS
QU52		
?	HT327852D0	Transistor 2SC2785(FF, EF)
QU62		

REF. DESIG.	PART NO.	DESCRIPTION
		PV00-VD INPUT CIRCUIT BOARD
PV00	YK290H1550	P.W. Board, VD Input
	ZZ290H1550	P.W. Board Assembly
CV01	DK18473310	Ceramic Cap. 0.047 μ F +80% -20% 50V
JV01	YT02030020	Terminal, 3P
WV01	YU03120260	Jumper Lead, 3P
		PW00-VCR EASY REMOTE INPUT CIRCUIT BOARD
PW00	YK290H1520	P.W. Board, VCR Easy Remote Input
	ZZ290H1520	P.W. Board Assembly
CW05	DK18473310	Ceramic Cap. 0.047 μ F
CW08	DK18473310	Ceramic Cap. 0.047 μ F
JW01	YT02040620	Terminal, 4P; VCR IN/OUT
JW02	YT02020340	Terminal, 2P; Remote IN/OUT
JW03	YT02020540	Terminal, 2P; Easy IN/OUT
JW04	YT02040590	Terminal, 4P; Surround IN/OUT
JW05	YQ01000080	Shote Plug
JW06	YQ01000080	Shote Plug
JW07	YJ07001750	Jack, 5P
SW01	SS01020520	Slide Switch, VCR Mono/Stereo
SW02	SS01020520	Slide Switch, Remote IN/OUT
WW01	YU06140260	Jumper Lead, 6P
WW02	YU06180260	Jumper Lead, 6P

(W01-99)	Assembly and Wiring
(T01-99)	Adjustment
(X01-00)	Correction

NOTE ON SAFETY:

Symbol \triangle Fire or electrical shock hazard. Only original parts should be used to replace any part marked with symbol \triangle . Any other component substitution (other than original type), may increase risk of fire or electrical shock hazard.

10. TECHNICAL SPECIFICATIONS

(Model PM451)

AUDIO SECTION

POWER OUTPUT PER CHANNEL

DIN 4 OHMS	80 W
RMS 4 OHMS	60 W
DIN 8 OHMS	70 W
RMS 8 OHMS	60 W
TOTAL HARMONIC DISTORTION AT RMS 8 OHMS	0.05%
I.M. DISTORTION	0.05%
DAMPING FACTOR 8 OHMS (1 kHz)	35

Frequency Response 10 Hz ~ 25 kHz

MM CARTRIDGE INPUT

Frequency Response (RIAA)	±0.5 dB
Signal to Noise Ratio	80 dB
Input Impedance	47 k ohms
Input Capacitance	330 pF
Input Sensitivity	2.5 mV
Equivalent Input Noise	1.6 μV
Dynamic Range	103 dB

AUX. INPUT

Input Impedance	22 k ohms
Input Sensitivity	150 mV
Frequency Response	10 Hz ~ 25 kHz
Signal to Noise Ratio	93 dB

OUTPUT VOLTAGE

Tape Out	150 mV
----------	--------

OUTPUT IMPEDANCE

Tape Out	550 ohms
----------	----------

GENERAL

Power Requirements	N and T versions	220/240 V AC, 50/60 Hz
	E version	110/120/220/240 V AC, 50/60 Hz
Power Consumption at Rated Output, both Channels Driven		270 W
Dimensions		
Panel Width		420 mm
Panel Height		118 mm
Depth		329 mm
Weight		
Unit Alone		8.3 kg

Specifications and appearance are subject to change for modification without notice.

(Model PM551)

AUDIO SECTION

POWER OUTPUT PER CHANNEL

DIN 4 OHMS	115 W
RMS 4 OHMS	100 W
DIN 8 OHMS	110 W
RMS 8 OHMS	100 W
TOTAL HARMONIC DISTORTION AT RMS 8 OHMS	0.05%
I.M. DISTORTION	0.05%
DAMPING FACTOR 8 OHMS (1 kHz)	35

Frequency Response 10 Hz ~ 25 kHz

MM CARTRIDGE INPUT

Frequency Response (RIAA)	±0.5 dB
Signal to Noise Ratio	80 dB
Input Impedance	47 k ohms
Input Capacitance	330 pF
Input Sensitivity	2.5 mV
Equivalent Input Noise	1.6 µV
Dynamic Range	103 dB

AUX. INPUT

Input Impedance	22 k ohms
Input Sensitivity	150 mV
Frequency Response	10 Hz ~ 25 kHz
Signal to Noise Ratio	95 dB

OUTPUT VOLTAGE

Tape Out 150 mV

OUTPUT IMPEDANCE

Tape Out 550 ohms

GENERAL

Power Requirements	N and T versions	220/240 V AC, 50/60 Hz
	E version	110/120/220/240 V AC, 50/60 Hz
Power Consumption at Rated Output, both Channels Driven		380 W
Dimensions		
Panel Width		420 mm
Panel Height		118 mm
Depth		329 mm
Weight		
Unit Alone		10.4 kg

Specifications and appearance are subject to change for modification without notice.

11. SCHEMATIC DIAGRAM

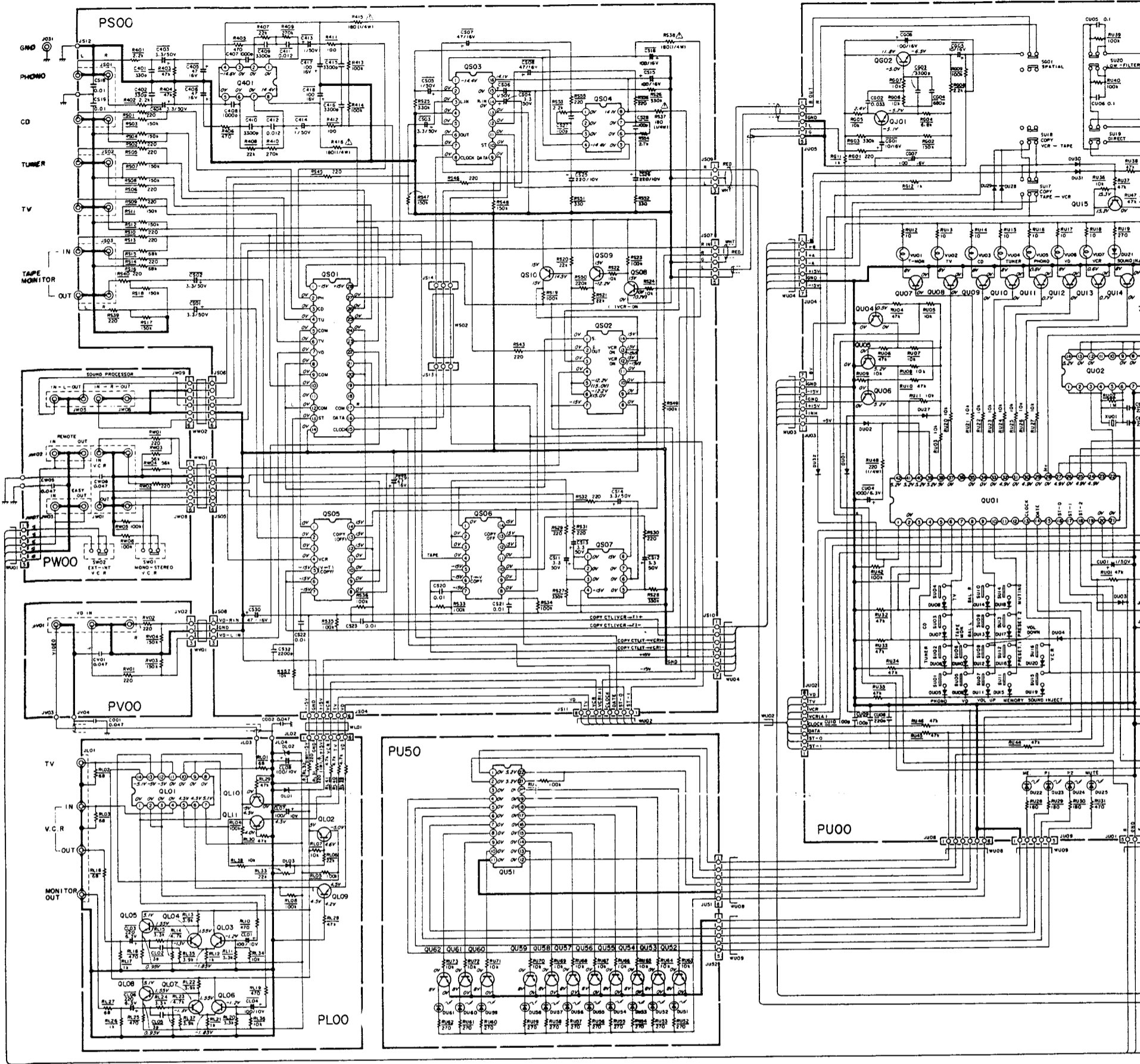

F001	FS10140800	FUSE 1.4A 250V
F002	FS10315800	FUSE 3.15A 250V [E]
L001	TS17631010	POWER TRANSF. [N, A]
L001	TS17631030	POWER TRANSF. [E]
ST01	SP04020480	PUSH SWITCH SPEAKER
ST02	SP01010960	PUSH SWITCH POWER
LN01	LY20240260	RELAY SPEAKER PROTECTOR

SG01	SP02011270	PUSH SWITCH
SU01		
	SP01011000	PUSH SWITCH
SU16		
SU17		
	SP02011270	PUSH SWITCH
SU20		
VU01		
	IN10080650	LAMP 8V 50 mA
VU07		
SW01	SS01020520	SLIDE SWITCH VCR
SW02	SS01020520	SLIDE SWITCH REMOTE
RF21	RY01040050	VARIABLE 100KΩ

M2971

NOTE ON SAFETY :

Symbol Δ Fire or electrical shock hazard. Only original parts should be used to replace any part marked with symbol Δ . Any other component substitution (other than original type), may increase risk of fire or electrical shock hazard.

Model PM451

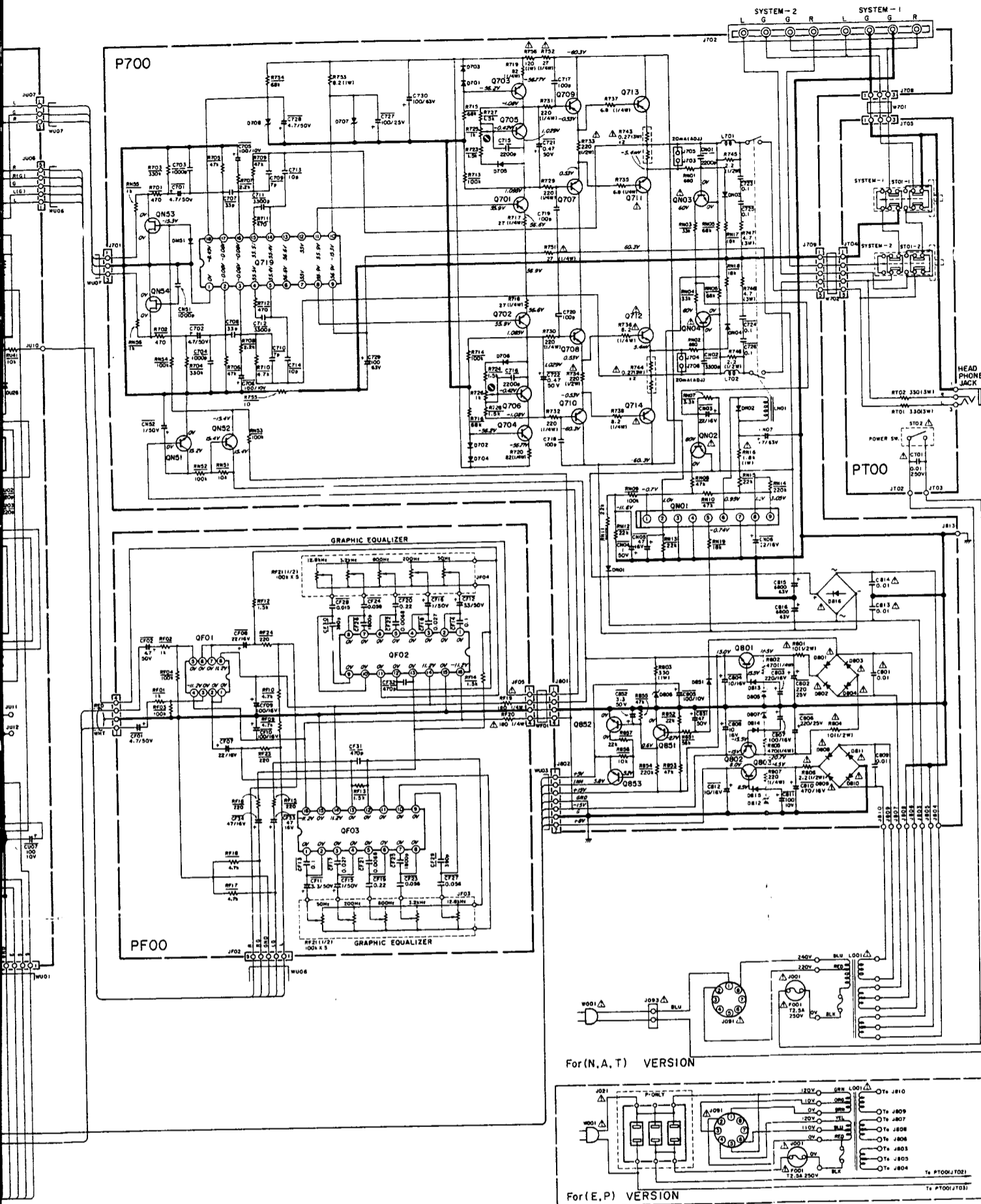

Q701, Q702 HT12082AO 2SA1208(R, S)	Q701 ~ Q706 DB13 ~ DB15 DL03, DN51 HD2001000 IS2473, IS1555 etc.		
Q703, Q704 HT329102AO 2SC2910(R, S)	Q707 HD30012020 MA1150		
Q707, Q708, Q801 Q803 HT332982DO 2SC298(Q, Y)	Q708 HD30024020 MA1082		
Q709, Q710, Q802 HT113062DO 2SA1306(Q, Y)	Q805, Q807 HD30020020 MA1160		
Q711, Q712 HT331822AO 2SC3182(R, O)	Q806 HD30005020 MA1056		
Q713, Q714 HT112852AO 2SA1285(R, O)	Q812 HD30007020 MA1091		
Q719 HC10066020 AN7062P	Q816 HE20009290 SSV820		
Q851, Q852 Q705, Q706, QN51 HT30945280 2SC945(Q, R)	Q801 ~ Q804 Q808 ~ Q811, Q851 HD20015030 DS1350		
Q853, Q854, Q855 QN52, Q809 ~ Q811 HT11752DO 2SA1175(FF, EF)	Q801, Q802 HD20022030 DSF10C		
QF01, Q401, Q504 Q507 HC10008090 NJM4508DO	Q803, Q804 HD20003210 IS2471		
QF02, QF03 HC10036200 MS227P	DU21 DU51 ~ DU61 MI10038030 SLP-281F		
QO01, QO02 QO3 ~ QO8 QU07 ~ QU14 QU52 ~ QU62 HT327852DO 2SC2785(FF, EF)	DU22 ~ DU24 HI10052030 SLP-2748		
QO03, QO04 HT322401AO 2SC2240(GR)	DU25 HI10053030 SLP-1748		
QO1 HC406603CO LC4066BH	QU01 ~ QU20 DU26 ~ DU29 QU12 HD20015211 ISS133		
QO1 HC10042050 TA7317P	QO1 HC406603CO LC4066BH		
QO2 HT109701AO 2SA970(GR)	QO1 HC10117050 TC9163M		
QO3, QO4 HF203722AO 2SK372(GR, BL)	QO2, QO5 HC10150030 LC4966		
QO1 HC10117050 TC9163M	QO3 HC10118050 TC9176P		
QO2 HT109701AO 2SA970(GR)	QU01 HC10169030 LC6502C		
QO3, QO4 HF203722AO 2SK372(GR, BL)	QU02 HC40110080 D40118C		
QO1 HC10117050 TC9163M	QU01 HC10001260 MSM59371RS		
QO2 HT109701AO 2SA970(GR)			
QO3, QO4 HF203722AO 2SK372(GR, BL)			

For (N.A.T) VERSION

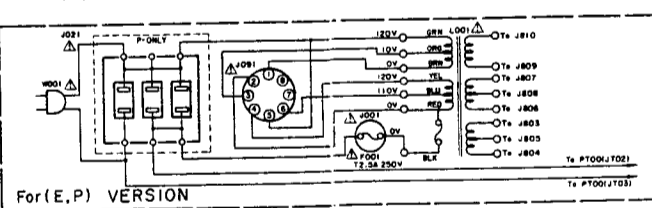

For (E.P) VERSION

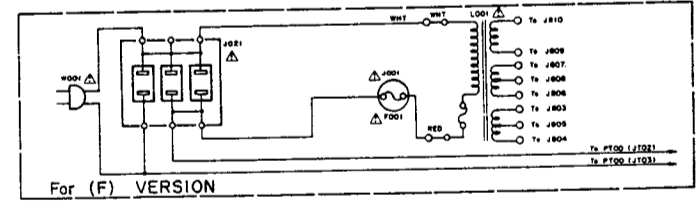

For (F) VERSION

"SERVICE INFORMATION IS FOR USE BY QUALIFIED PERSONNEL ONLY - ANY MISADJUSTMENT OR MISALIGNMENT MAY BE TREATED AS A NON-WARRANTY REPAIR BY ANY MARANTZ SERVICE CENTRE -"

Kind of Common Parts

- RESISTOR**
- R*** (1) GD05 --- 140, Carbon film fixed resistor, ±5% 1/4W
 - R*** (2) GD05 --- 160, Carbon film fixed resistor, ±5% 1/6W
- CERAMIC CAP.**
- DD1 --- 370, Ceramic condenser, disc type (titan condenser) Temp. coeff. P350 ~ N1000 50V
 - DK16 --- 300, High dielectric constant ceramic condenser, disc type (titan variable) Temp. chara. 2B4 50V

- ELECTROLY CAP. (E) / FILM CAP. (F)**
- (1) EA --- 10, Electrolytic condenser, one-way lead type, tolerance ±20%
 - (2) DF15 --- 350, Plastic film condenser, one-way type, Mylar, ±5% 50V

* In case of ordering the common parts, please establish the correct parts number of 10 figures by the procedure "ASSIGNMENT OF COMMON PARTS CODES"

... are subject to change for modification without notice.

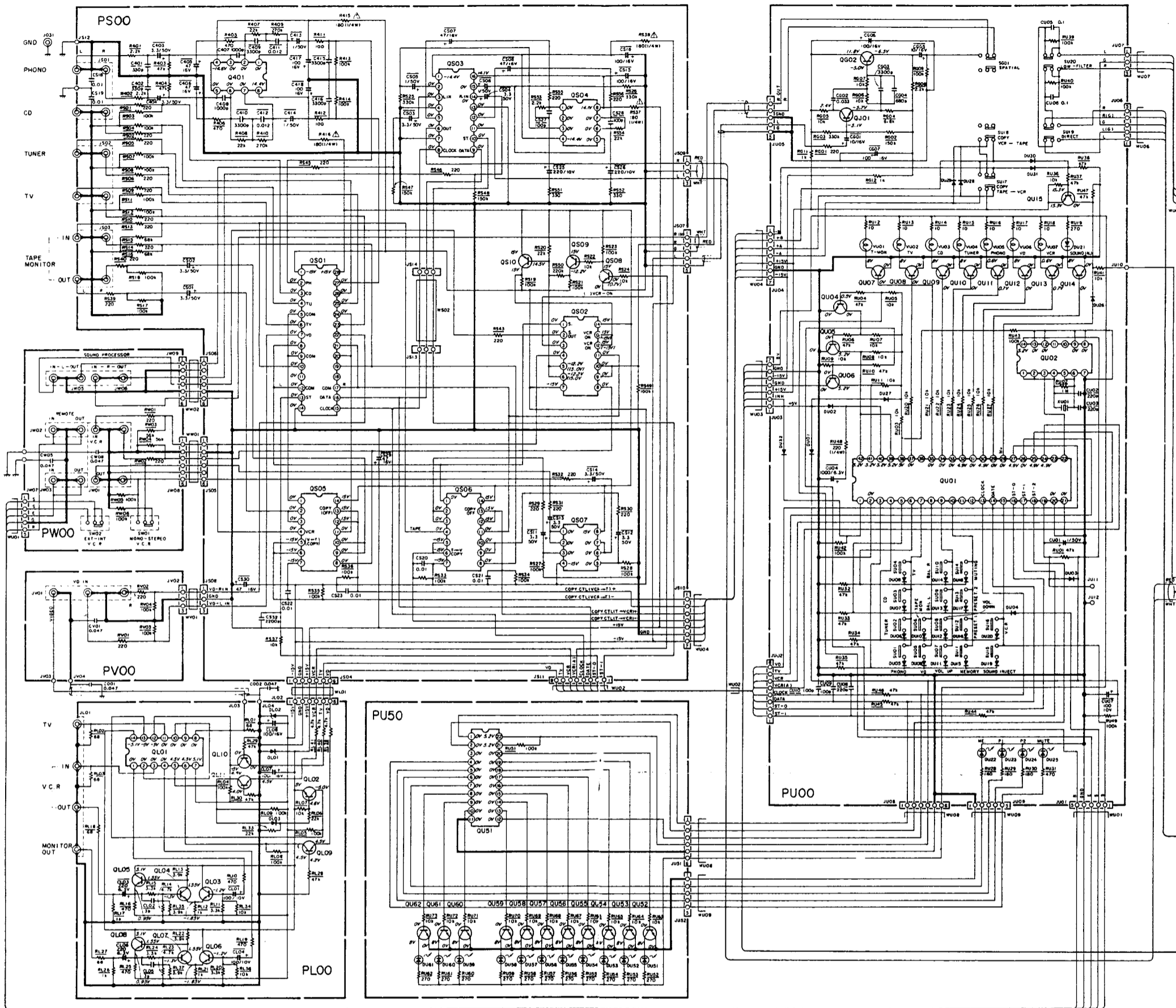

F001	FS10250800	FUSE 2.5A 250V [N, E, A]
F001	FS10600500	FUSE 6A 250V [U, C]
F001	FS1050800	FUSE 5A 250V [P]
F002	FS1050800	FUSE 5A 250V [E]
F002	FS10250800	FUSE 2.5A 250V [P]
L001	TS19624030	POWER TRANSF. [N, A]
L001	TS19624020	POWER TRANSF. [U, C]
L001	TS19624040	POWER TRANSF. [E]
ST01	SP04020480	PUSH SWITCH SPEAKER
ST02	SP01010960	PUSH SWITCH POWER
LN01	LY20240190	RELAY SPEAKER PROTECTOR

SG01	SP02011270	PUSH SWITCH
SU01	?	SP01011000
SU16		PUSH SWITCH
SU17		PUSH SWITCH
?	SP02011270	PUSH SWITCH
SU20		PUSH SWITCH
VU01		PUSH SWITCH
?	IN10080650	LAMP 8V 50 mA
VU07		LAMP 8V 50 mA
SW01	SS01020520	SLIDE SWITCH VCR
SW02	SS01020520	SLIDE SWITCH REMOTE
RF21	RY01040050	VARIABLE 100KΩ

NOTE ON SAFETY :
 Symbol Δ Fire or electrical shock hazard. Only original parts should be used to replace any part marked with symbol Δ . Any other component substitution (other than original type), may increase risk of fire or electrical shock hazard.

Components and wiring are subject to

Model PM551

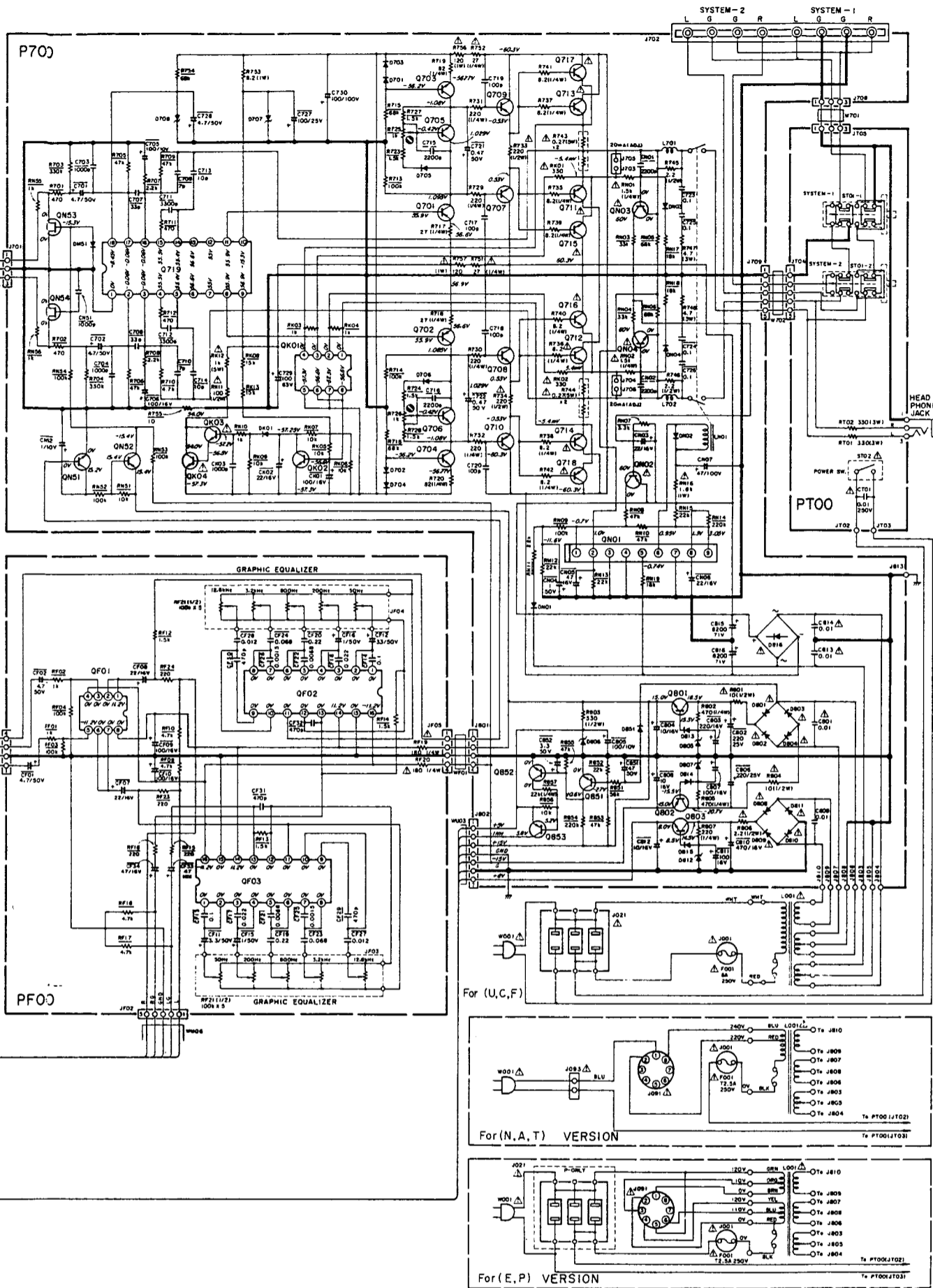

- Q701, Q702
HT112082AO
2SA1208(R, S)
- Q703, Q704
HT329102AO
2SC2910(R, S)
- Q707, Q708, Q801
Q803
HT33298200
2SC2981(O, Y)
- Q709, Q710, Q802
HT11306200
2SA1306(O, Y)
- Q711, Q712, Q715
Q716
HT331822AO
2SC3182(R, O)
- Q713, Q714, Q717
Q718
HT112652AO
2SA1265(R, O)
- Q719
HC10066020
AN7062P
- Q851, Q852, Q802
Q705, Q706, Q851
HT30943280
2SC945(O, R)
- Q853, Q802, Q815
Q822, Q809~Q811
HT11175200
2SA1175(FF, EF)
- QF01, Q401, Q504
Q507
HC10008090
NJM4558DD
- QF02, QF03
HC10036200
M5227P
- Q601, Q602
Q603~Q608
Q607~Q614
Q652~Q656
HT32765200
2SC2765(FF, EF)
- QK01
HC10004320
PC-827
- QK03
QK04
HT322401AO
2SC2240(GR)
- QLO1
HC406603CO
LC4066BH
- QNO1
HC10042050
TA7317P
- QNO2
HT09701AO
2SA970(GR)
- QNS3, QNS4
HF203722AO
2SK372(GR, BL)
- QSO1
HC10117050
TC9163N
- QSO2, QSO5
HC10150030
LC4966
- QSO3
HC10118050
TC9176P
- QU01
HC10169030
LC6502C
- QU02
HC40110080
D40118C
- QU51
HC10001260
MSM59371RS
- QK03, QK04
HT32551100
2SC2551(O)
- D701~D706
D813~D815
DK01, DL05, DN51
HO20001000
IS2473, IS1555 etc.
- D707
HD30012020
MA1150
- D708
HD30024020
MA1082
- D805, D807
HD30020020
MA1160
- D806
HD30005020
MA1056
- D812
HD30007020
MA1091
- D816
HE20012290
D5F820
- D801~D804
D808~D811, D851
HD20015030
DS1350
- DL01, DL02
HD30004020
MA1051M
- DN01, DN02
HD20022030
DSF10C
- DN03, DN04
HD20003210
IS2471
- DU21
DU51~DU61
HI10038030
SLP-281F
- DU22~DU24
HI10052030
SLP-274B
- DU25
HI10053030
SLP-174B
- DU01~DU20
DU26~DU29
DU32
HD20015211
IS1313
- QK01, QK02
TC9163N
- QK03, QK04
TC9176P
- QK05, QK06
TC9163N
- QK07, QK08
TC9176P
- QK09, QK10
TC9163N
- QK11, QK12
TC9176P
- QK13, QK14
TC9163N
- QK15, QK16
TC9176P
- QK17, QK18
TC9163N
- QK19, QK20
TC9176P
- QK21, QK22
TC9163N
- QK23, QK24
TC9176P
- QK25, QK26
TC9163N
- QK27, QK28
TC9176P
- QK29, QK30
TC9163N
- QK31, QK32
TC9176P
- QK33, QK34
TC9163N
- QK35, QK36
TC9176P
- QK37, QK38
TC9163N
- QK39, QK40
TC9176P
- QK41, QK42
TC9163N
- QK43, QK44
TC9176P
- QK45, QK46
TC9163N
- QK47, QK48
TC9176P
- QK49, QK50
TC9163N
- QK51, QK52
TC9176P
- QK53, QK54
TC9163N
- QK55, QK56
TC9176P
- QK57, QK58
TC9163N
- QK59, QK60
TC9176P
- QK61, QK62
TC9163N
- QK63, QK64
TC9176P
- QK65, QK66
TC9163N
- QK67, QK68
TC9176P
- QK69, QK70
TC9163N
- QK71, QK72
TC9176P
- QK73, QK74
TC9163N
- QK75, QK76
TC9176P
- QK77, QK78
TC9163N
- QK79, QK80
TC9176P
- QK81, QK82
TC9163N
- QK83, QK84
TC9176P
- QK85, QK86
TC9163N
- QK87, QK88
TC9176P
- QK89, QK90
TC9163N
- QK91, QK92
TC9176P
- QK93, QK94
TC9163N
- QK95, QK96
TC9176P
- QK97, QK98
TC9163N
- QK99, QK100
TC9176P

"SERVICE INFORMATION IS FOR USE BY QUALIFIED PERSONNEL ONLY - ANY MISADJUSTMENT OR MISALIGNMENT MAY BE TREATED AS A NON-WARRANTY REPAIR BY ANY MARANTZ SERVICE CENTRE -"

Kind of Common Parts

- RESISTOR**
- R*** (1) GD05 --- 140, Carbon film fixed resistor, ±5% 1/4W
 - R*** (2) GD05 --- 160, Carbon film fixed resistor, ±5% 1/6W
- C*** : CERAMIC CAP.**
- (1) DD1 ---- 370, Ceramic condenser, disc type (titan condenser) Temp. coeff. P350~N1000 50V
- C*** : CERAMIC CAP.**
- (1) DK16 --- 300, High dielectric constant ceramic condenser, disc type (titan variable) Temp. chara. 2B4 50V

- C*** : ELECTROLY CAP. (≡) / FILM CAP. (≡)**
- (1) EA ----- 10, Electrolytic condenser, one-way lead type, tolerance ±20%
 - (2) DF15 --- 350, Plastic film condenser, one-way type, Mylar, ±5% 50V

* In case of ordering the common parts, please establish the correct parts number of 10 figures by the procedure "ASSIGNMENT OF COMMON PARTS CODES"

do not change for modification without notice.

M2972